

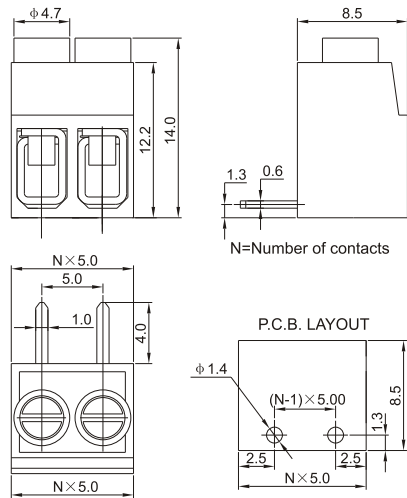

DG167R



Pitch:5mm

● **材质及电镀**

螺丝 : M2.5, 钢, 镀锌
触点材料: 磷青铜
焊针 : 黄铜, 镀锡
塑件 : PA66, UL94V-0

● **电气性能**

额定电压 : 300V
额定电流 : 15A
接触电阻 : 20mΩ
绝缘电阻 : 5000MΩ/1000V
耐电压 : AC1500V/1Min
使用线径 : 22-12AWG 2.5mm²

● **机械性能**

温度范围 : -40°C~+105°C
瞬时温度 : +250°C 5秒
扭矩 : 0.4Nm(3.6lb.in)
剥线长度 : 6-7mm

● **Material**

Screws : M2.5 steel Zinc plated
Contact : Phosphor bronze
Pin header : Brass, Tin plated
Housing : PBT, UL94V-0

● **Electrical**

Rated voltage : 300V
Rated current : 15A
Contact resistance : 20mΩ
Insulation resistance: 5000MΩ/1000V
Withstanding voltage: AC1500V/1Min
Wire range : 22-12AWG 2.5mm²

● **Mechanical**

Temp.Range : -40°C~+105°C
MAX Soldering: +250°C, for 5 Sec.
Torque : 0.4Nm(3.6lb.in)
Strip length : 6-7mm



DG308

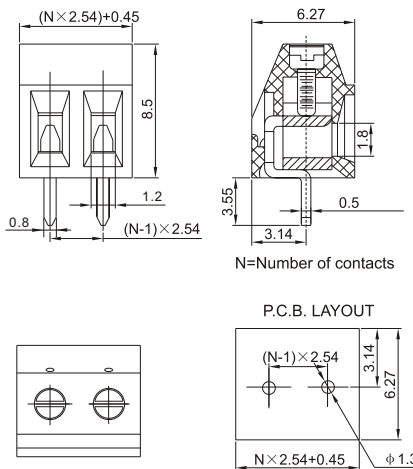

Pitch:2.54mm

● **材质及电镀**

螺丝 : M1.5, 钢, 镀锌
触点材料: 黄铜
焊针 : 黄铜, 镀锡
塑件 : PA66, UL94V-0

● **电气性能**

额定电压 : 300V
额定电流 : 8A
接触电阻 : 20mΩ
绝缘电阻 : 5000MΩ/1000V
耐电压 : AC1500V/1Min
使用线径 : 26-18AWG 1mm²

● **机械性能**

温度范围 : -40°C~+105°C
瞬时温度 : +250°C 5秒
扭矩 : 0.15Nm(1.3lb.in)
剥线长度 : 3.7-4.7mm

● **Material**

Screws : M1.5 steel Zinc plated
Contact : Phosphor bronze
Pin header : Brass, Tin plated
Housing : PBT, UL94V-0

● **Electrical**

Rated voltage : 300V
Rated current : 8A
Contact resistance : 20mΩ
Insulation resistance: 5000MΩ/1000V
Withstanding voltage: AC1500V/1Min
Wire range : 26-18AWG 1mm²

● **Mechanical**

Temp.Range : -40°C~+105°C
MAX Soldering: +250°C, for 5 Sec.
Torque : 0.15Nm(1.3lb.in)
Strip length : 3.7-4.7mm



DG103

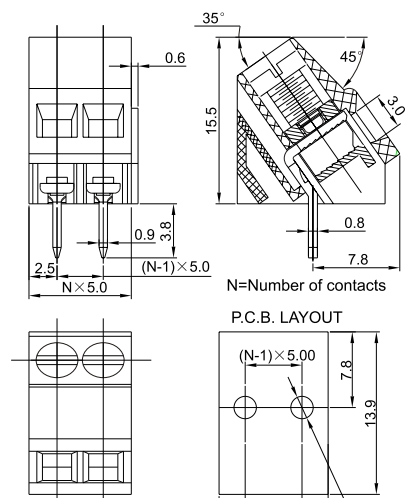

Pitch:5mm

● **材质及电镀**

螺丝 : M2.5, 钢, 镀锌
触点材料: 黄铜
焊针 : 黄铜, 镀锡
塑件 : PA66, UL94V-0

● **电气性能**

额定电压 : 300V
额定电流 : 10A
接触电阻 : 20mΩ
绝缘电阻 : 5000MΩ/1000V
耐电压 : AC1500V/1Min
使用线径 : 24-12AWG 2.5mm²

● **机械性能**

温度范围 : -40°C~+105°C
瞬时温度 : +250°C 5秒
扭矩 : 0.4Nm(3.6lb.in)
剥线长度 : 6-7mm

● **Material**

Screws : M2.5 steel Zinc plated
Contact : Brass
Pin header : Brass, Tin plated
Housing : PA66, UL94V-0

● **Electrical**

Rated voltage : 300V
Rated current : 10A
Contact resistance : 20mΩ
Insulation resistance: 5000MΩ/1000V
Withstanding voltage: AC1500V/1Min
Wire range : 24-12AWG 2.5mm²

● **Mechanical**

Temp.Range : -40°C~+105°C
MAX Soldering: +250°C, for 5 Sec.
Torque : 0.4Nm(3.6lb.in)
Strip length : 6-7mm