

# BUZZER

## Magnetic Transducer Buzzer Series

KLS3-MT-12\*8.5 Φ12\*8.5mm Magnetic Transducer Buzzer Series

### SPECIFICATIONS

Item No.	MT-12*8.5-A	MT-12*8.5-B	MT-12*8.5-C
Rated Voltage	1.5V	1.5V	1.5V
Operating Voltage	1-2V	1-2V	1-2V
Max. Rated Current	30mA	10mA	10mA
Min. S.P.L. (@ 10cm)	85dB	80dB	80dB
Coil Resistance (DC)	16±4Ω	42±6Ω	50±7.5Ω
Resonant Frequency	2048Hz		
Operating Temp	-20 ~ +70 °C		
Weight	2g		



Dimensions (Unit:mm)

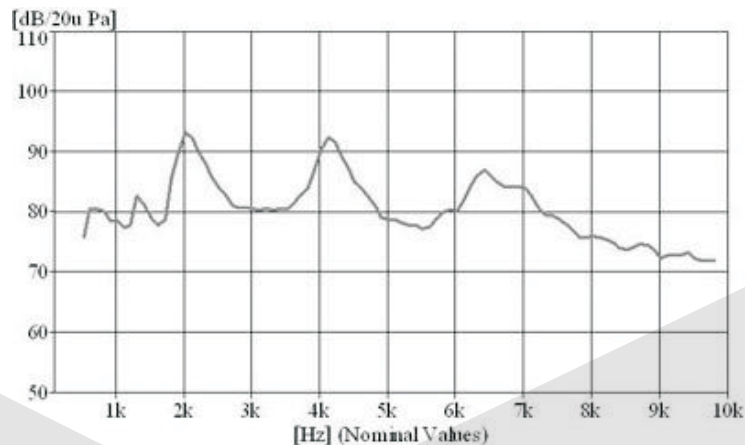
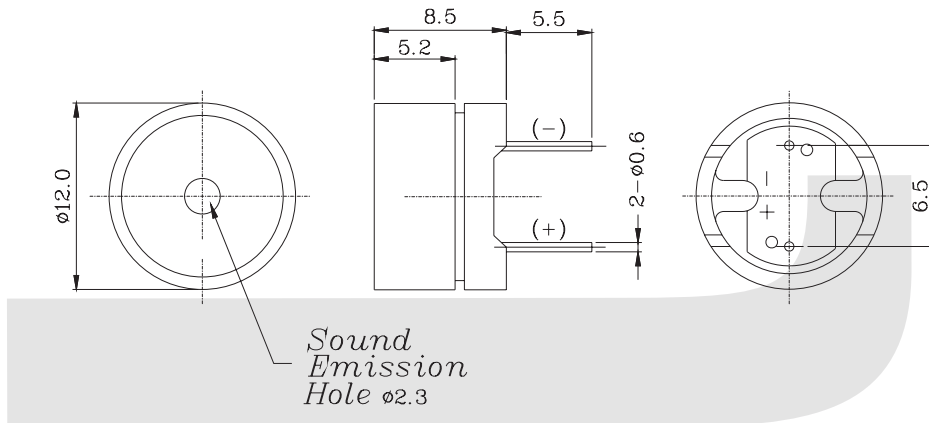

### ORDER INFORMATION

Product NO.: **KLS3- MT - 12\*8.5 - A**

Part Number

Magnetic Transducer Buzzer Series

Coil Resistance: A=16Ω B=42Ω C=50Ω

Size specifications