

FEATURES

- High Accuracy, Supports IEC 687/1036**
- Less than 0.1% Error over a Dynamic Range of 1000 to 1**
- An On-Chip User Programmable Threshold for Line Voltage SAG Detection and PSU Supervisory**
- The ADE7756 Supplies Sampled Waveform Data (20 Bits) and Active Energy (40 Bits)**
- Digital Power, Phase and Input Offset Calibration**
- An On-Chip Temperature Sensor ($\pm 3^{\circ}\text{C}$ Typical after Calibration)**
- An SPI-Compatible Serial Interface**
- A Pulse Output with Programmable Frequency**
- An Interrupt Request Pin (IRQ) and Status Register**
- Provide Early Warning of Register Overflow and Other Conditions**
- Proprietary ADCs and DSP Provide High Accuracy over Large Variations in Environmental Conditions and Time**
- Reference $2.4\text{ V} \pm 8\%$ (20 ppm/ $^{\circ}\text{C}$ Typical) with External Overdrive Capability**
- Single 5 V Supply, Low Power (25 mW Typical)**

GENERAL DESCRIPTION

The ADE7756 is a high-accuracy electrical power measurement IC with a serial interface and a pulse output. The ADE7756 incorporates two second-order sigma-delta ADCs, reference circuitry, temperature sensor, and all the signal processing required to perform active power and energy measurement.

The ADE7756 contains a sampled Waveform register and an Active Energy register capable of holding at least five seconds of accumulated power at full load. Data is read from the ADE7756 via the serial interface. The ADE7756 also provides a pulse output (CF) with a frequency that is proportional to the active power.

In addition to real power information, the ADE7756 also provides system calibration features, i.e., channel offset correction, phase calibration, and power calibration. The part also incorporates a detection circuit for short duration low voltage variations or sags. The voltage threshold level and the duration (in number of half-line cycles) of the variation are user programmable. An open drain logic output (SAG) goes active low when a sag event occurs.

A zero crossing output (ZX) produces an output that is synchronized to the zero crossing point of the line voltage. This output can be used to extract timing or frequency information from the line. The signal is also used internally to the chip in the calibration mode. This permits faster and more accurate calibration of the real power calculation. This signal is also useful for synchronization of relay switching with a voltage zero crossing, thus improving the relay life by reducing the risk of arcing.

The interrupt request output is an open drain, active low logic output. The $\overline{\text{IRQ}}$ output will become active when the accumulated real power register is half-full and also when the register overflows. A status register indicates the nature of the interrupt.

The ADE7756 is available in 20-lead DIP and 20-lead SSOP packages.

FUNCTIONAL BLOCK DIAGRAM

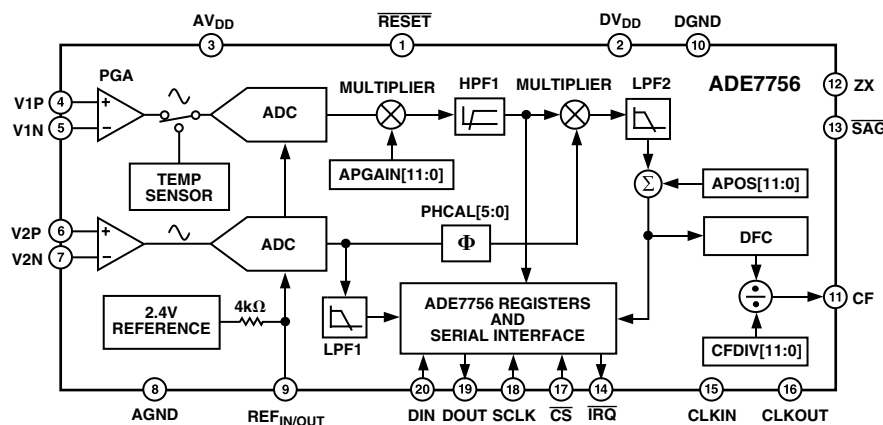

*U.S. Patents 5,745,323; 5,760,617; 5,862,069; 5,872,469; other pending.

REV. 0

Information furnished by Analog Devices is believed to be accurate and reliable. However, no responsibility is assumed by Analog Devices for its use, nor for any infringements of patents or other rights of third parties that may result from its use. No license is granted by implication or otherwise under any patent or patent rights of Analog Devices.

ADE7756

TABLE OF CONTENTS

FEATURES	1	Reference Circuit	17
GENERAL DESCRIPTION	1	CHANNEL 1 ADC	18
FUNCTIONAL BLOCK DIAGRAM	1	Channel 1 ADC Gain Adjust	18
ADE7756-SPECIFICATIONS	3	Channel 1 Sampling	18
TIMING CHARACTERISTICS	5	CHANNEL 2 ADC	19
ABSOLUTE MAXIMUM RATINGS	6	Channel 2 Sampling	19
ORDERING GUIDE	6	PHASE COMPENSATION	20
PIN CONFIGURATION	6	ACTIVE POWER CALCULATION	21
PIN FUNCTION DESCRIPTIONS	6	ENERGY CALCULATION	22
TERMINOLOGY	8	Integration Times under Steady Load	23
MEASUREMENT ERROR	8	POWER OFFSET CALIBRATION	23
PHASE ERROR BETWEEN CHANNELS	8	ENERGY-TO-FREQUENCY CONVERSION	23
POWER SUPPLY REJECTION	8	ENERGY CALIBRATION	24
ADC OFFSET ERROR	8	CALIBRATING THE ENERGY METER	24
GAIN ERROR	8	Calculating the Average Active Power	24
GAIN ERROR MATCH	8	Calibrating the Frequency at CF	24
ANALOG INPUTS	12	Energy Meter Display	25
ZERO CROSSING DETECTION	13	CLKIN FREQUENCY	25
LINE VOLTAGE SAG DETECTION	14	APPLICATION INFORMATION	25
Sag Level Set	14	SUSPENDING THE ADE7756 FUNCTIONALITY	26
POWER SUPPLY MONITOR	14	SERIAL INTERFACE	26
INTERRUPTS	15	Serial Write Operation	27
Using the ADE7756 Interrupts with an MCU	15	Serial Read Operation	27
Interrupt Timing	15	REGISTER DESCRIPTIONS	29
TEMPERATURE MEASUREMENT	16	Communications Register	29
ANALOG-TO-DIGITAL CONVERSION	16	Mode Register (06H)	30
Antialias Filter	17	Interrupt Status Register (04H)/Reset Interrupt	
ADC Transfer Function	17	Status Register (05H)	31
		OUTLINE DIMENSIONS	32

SPECIFICATIONS¹ ($AV_{DD} = DV_{DD} = 5\text{ V} \pm 5\%$, $AGND = DGND = 0\text{ V}$, On-Chip Reference, $CLKIN = 3.579545\text{ MHz XTAL}$, T_{MIN} to $T_{MAX} = -40^{\circ}\text{C}$ to $+85^{\circ}\text{C}$, unless otherwise noted.)

Parameter	A Version	B Version	Unit	Test Conditions/Comments
ENERGY MEASUREMENT ACCURACY				
Measurement Bandwidth	14	14	kHz	CLKIN = 3.579545 MHz
Measurement Error ¹ on Channel 1				Channel 2 = 300 mV rms/60 Hz, Gain = 2
Channel 1 Range = 1 V Full Scale				
Gain = 1	0.1	0.1	% typ	Over a Dynamic Range 1000 to 1
Gain = 2	0.1	0.1	% typ	Over a Dynamic Range 1000 to 1
Gain = 4	0.1	0.1	% typ	Over a Dynamic Range 1000 to 1
Gain = 8	0.1	0.1	% typ	Over a Dynamic Range 1000 to 1
Gain = 16	0.1	0.1	% typ	Over a Dynamic Range 1000 to 1
Channel 1 Range = 0.5 V Full Scale				
Gain = 1	0.1	0.1	% typ	Over a Dynamic Range 1000 to 1
Gain = 2	0.1	0.1	% typ	Over a Dynamic Range 1000 to 1
Gain = 4	0.1	0.1	% typ	Over a Dynamic Range 1000 to 1
Gain = 8	0.1	0.1	% typ	Over a Dynamic Range 1000 to 1
Gain = 16	0.2	0.2	% typ	Over a Dynamic Range 1000 to 1
Channel 1 Range = 0.25 V Full Scale				
Gain = 1	0.1	0.1	% typ	Over a Dynamic Range 1000 to 1
Gain = 2	0.1	0.1	% typ	Over a Dynamic Range 1000 to 1
Gain = 4	0.1	0.1	% typ	Over a Dynamic Range 1000 to 1
Gain = 8	0.2	0.2	% typ	Over a Dynamic Range 1000 to 1
Gain = 16	0.2	0.2	% typ	Over a Dynamic Range 1000 to 1
Phase Error ¹ Between Channels	± 0.05	± 0.05	$^{\circ}$ max	Line Frequency = 45 Hz to 65 Hz, HPF On
AC Power Supply Rejection ¹				$AV_{DD} = DV_{DD} = 5\text{ V} + 175\text{ mV rms}/120\text{ Hz}$
Output Frequency Variation (CF)	0.2	0.2	% typ	Channel 1 = 20 mV rms/60 Hz, Gain = 16, Range = 0.5 V
DC Power Supply Rejection ¹				Channel 2 = 175 mV rms/60 Hz, Gain = 4
Output Frequency Variation (CF)	± 0.3	± 0.3	% typ	$AV_{DD} = DV_{DD} = 5\text{ V} \pm 250\text{ mV dc}$
				Channel 1 = 20 mV rms/60 Hz, Gain = 16, Range = 0.5 V
				Channel 2 = 175 mV rms/60 Hz, Gain = 4
ANALOG INPUTS				
Maximum Signal Levels	± 1	± 1	V max	See Analog Inputs Section
Input Impedance (dc)	390	390	k Ω min	V1P, V1N, V2N and V2P to AGND
Bandwidth	14	14	kHz	CLKIN/256, CLKIN = 3.579545 MHz
Gain Error ^{1, 2}				External 2.5 V Reference, Gain = 1 on Channel 1 and 2
Channel 1				
Range = 1 V Full Scale	± 4	± 4	% typ	V1 = 1 V dc
Range = 0.5 V Full Scale	± 4	± 4	% typ	V1 = 0.5 V dc
Range = 0.25 V Full Scale	± 4	± 4	% typ	V1 = 0.25 V dc
Channel 2	± 4	± 4	% typ	V2 = 1 V dc
Gain Error Match ¹				External 2.5 V Reference
Channel 1				
Range = 1 V Full Scale	± 0.3	± 0.3	% typ	Gain = 1, 2, 4, 8, 16
Range = 0.5 V Full Scale	± 0.3	± 0.3	% typ	Gain = 1, 2, 4, 8, 16
Range = 0.25 V Full Scale	± 0.3	± 0.3	% typ	Gain = 1, 2, 4, 8, 16
Channel 2	± 0.3	± 0.3	% typ	Gain = 1, 2, 4, 8, 16
Offset Error ¹				
Channel 1	± 20	± 20	mV max	Range = 1 V, Gain = 1
Channel 2	± 20	± 20	mV max	Gain = 1
WAVEFORM SAMPLING				
Channel 1				Sampling CLKIN/128, 3.579545 MHz/128 = 27.9 kSPS
Signal-to-Noise Plus Distortion	62	62	dB typ	See Channel 1 Sampling
Bandwidth (-3 dB)	14	14	kHz	700 mV rms/60 Hz, Range = 1 V, Gain = 1
Channel 2				CLKIN = 3.579545 MHz
Signal-to-Noise Plus Distortion	52	52	dB typ	See Channel 2 Sampling
Bandwidth (-3 dB)	156	156	Hz	300 mV rms/60 Hz, Gain = 2
				CLKIN = 3.579545 MHz

ADE7756—SPECIFICATIONS

Parameter	A Version	B Version	Unit	Test Conditions/Comments
REFERENCE INPUT				
REF _{IN/OUT} Input Voltage Range	2.6 2.2	2.6 2.2	V max V min	2.4 V + 8% 2.4 V – 8%
Input Capacitance	10	10	pF max	
ON-CHIP REFERENCE				Nominal 2.4 V at REF _{IN/OUT} Pin
Reference Error	±200	±200	mV max	
Load Current	10	10	μA max	
Output Impedance	4	4	kΩ min	
Temperature Coefficient	±20	±20 ±80	ppm/°C typ ppm/°C max	
CLKIN				Note All Specifications CLKIN of 3.579545 MHz
Input Clock Frequency	10 1	10 1	MHz max MHz min	
LOGIC INPUTS				
RESET, DIN, SCLK, CLKIN and CS				
Input High Voltage, V _{INH}	2.4	2.4	V min	DV _{DD} = 5 V ± 5%
Input Low Voltage, V _{INL}	0.8	0.8	V max	DV _{DD} = 5 V ± 5%
Input Current, I _{IN}	±3	±3	μA max	Typically 10 nA, V _{IN} = 0 V to DV _{DD}
Input Capacitance, C _{IN}	10	10	pF max	
LOGIC OUTPUTS				
SAG and IRQ				Open Drain Outputs, 10 kΩ Pull-Up Resistor
Output High Voltage, V _{OH}	4	4	V min	I _{SOURCE} = 5 mA
Output Low Voltage, V _{OL}	0.4	0.4	V max	I _{SINK} = 0.8 mA
ZX and DOUT				
Output High Voltage, V _{OH}	4	4	V min	I _{SOURCE} = 5 mA
Output Low Voltage, V _{OL}	0.4	0.4	V max	I _{SINK} = 0.8 mA
CF				
Output High Voltage, V _{OH}	4	4	V min	I _{SOURCE} = 5 mA
Output Low Voltage, V _{OL}	0.4	0.4	V max	I _{SINK} = 7 mA
POWER SUPPLY				For Specified Performance
AV _{DD}	4.75 5.25	4.75 5.25	V min V max	5 V – 5% 5 V + 5%
DV _{DD}	4.75 5.25	4.75 5.25	V min V max	5 V – 5% 5 V + 5%
AI _{DD}	3	3	mA max	Typically 2.0 mA
DI _{DD}	4	4	mA max	Typically 3.0 mA

NOTES

¹See Terminology section for explanation of specifications.

²See plots in Typical Performance Characteristic curves.

³See Analog Inputs section.

Specifications subject to change without notice

TIMING CHARACTERISTICS^{1, 2} ($V_{DD} = DV_{DD} = 5 V \pm 5\%$, $AGND = DGND = 0 V$, On-Chip Reference, $CLKIN = 3.579545 MHz$ XTAL, T_{MIN} to $T_{MAX} = -40^{\circ}C$ to $+85^{\circ}C$, unless otherwise noted.)

Parameter	A, B Versions	Unit	Test Conditions/Comments
Write Timing			
t_1	20	ns (min)	\overline{CS} falling edge to first SCLK falling edge.
t_2	150	ns (min)	SCLK logic high pulsewidth.
t_3	150	ns (min)	SCLK logic low pulsewidth.
t_4	10	ns (min)	Valid Data Setup time before falling edge of SCLK.
t_5	5	ns (min)	Data Hold time after SCLK falling edge.
t_6	6.4	μs (min)	Minimum time between the end of data byte transfers.
t_7	4	μs (min)	Minimum time between byte transfers during a serial write.
t_8	100	ns (min)	\overline{CS} Hold time after SCLK falling edge.
Read Timing			
t_9	4	μs (min)	Minimum time between read command (i.e., a write to Communication Register) and data read.
t_{10}	4	μs (min)	Minimum time between data byte transfers during a multibyte read.
t_{11}^3	30	ns (min)	Data access time after SCLK rising edge following a write to the Communications Register.
t_{12}^4	100	ns (max)	Bus relinquish time after falling edge of SCLK.
	10	ns (min)	
t_{13}^4	100	ns (max)	Bus relinquish time after rising edge of \overline{CS} .
	10	ns (min)	

NOTES

¹Sample tested during initial release and after any redesign or process change that may affect this parameter. All input signals are specified with $t_r = t_f = 5 ns$ (10% to 90%) and timed from a voltage level of 1.6 V.

²See timing diagram below and Serial Interface section of this data sheet.

³Measured with the load circuit in *Load Circuit for Timing Specifications* and defined as the time required for the output to cross 0.8 V or 2.4 V.

⁴Derived from the measured time taken by the data outputs to change 0.5 V when loaded with the circuit in *Load Circuit for Timing Specifications*. The measured number is then extrapolated back to remove the effects of charging or discharging the 50 pF capacitor. This means that the time quoted in the timing characteristics is the true bus relinquish time of the part and is independent of the bus loading.

Specifications subject to change without notice.

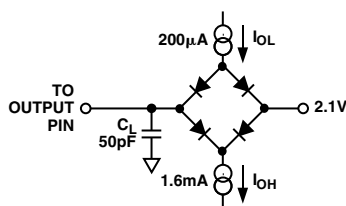

Figure 1. Load Circuit for Timing Specifications

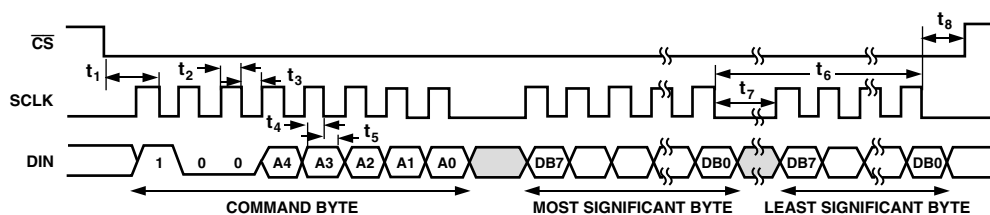

Figure 2. Serial Write Timing

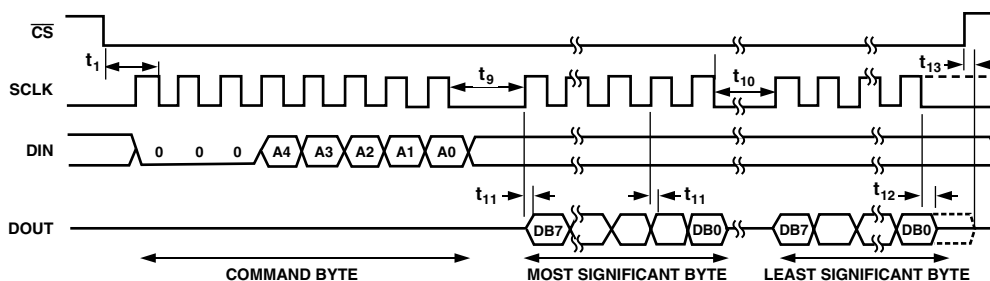

Figure 3. Serial Read Timing

ADE7756

ABSOLUTE MAXIMUM RATINGS*

(T_A = 25°C unless otherwise noted)

AV _{DD} to AGND	-0.3 V to +7 V
DV _{DD} to DGND	-0.3 V to +7 V
DV _{DD} to AV _{DD}	-0.3 V to +0.3 V
Analog Input Voltage to AGND		
V _{1P} , V _{1N} , V _{2P} and V _{2N}	-6 V to +6 V
Reference Input Voltage to AGND	...	-0.3 V to AV _{DD} + 0.3 V
Digital Input Voltage to DGND	...	-0.3 V to DV _{DD} + 0.3 V
Digital Output Voltage to DGND	...	-0.3 V to DV _{DD} + 0.3 V
Operating Temperature Range		
Industrial (A, B Versions)	-40°C to +85°C
Storage Temperature Range	-65°C to +150°C

Junction Temperature	150°C
20-Lead Plastic DIP, Power Dissipation	450 mW
θ _{JA} Thermal Impedance	105°C/W
Lead Temperature, (Soldering 10 sec)	260°C
20-Lead SSOP, Power Dissipation	450 mW
θ _{JA} Thermal Impedance	112°C/W
Lead Temperature, Soldering		
Vapor Phase (60 sec)	215°C
Infrared (15 sec)	220°C

*Stresses above those listed under Absolute Maximum Ratings may cause permanent damage to the device. This is a stress rating only; functional operation of the device at these or any other conditions above those listed in the operational sections of this specification is not implied. Exposure to absolute maximum rating conditions for extended periods may affect device reliability.

CAUTION

ESD (electrostatic discharge) sensitive device. Electrostatic charges as high as 4000 V readily accumulate on the human body and test equipment and can discharge without detection. Although the ADE7756 features proprietary ESD protection circuitry, permanent damage may occur on devices subjected to high-energy electrostatic discharges. Therefore, proper ESD precautions are recommended to avoid performance degradation or loss of functionality.



ORDERING GUIDE

Model	Package Description	Package Option
ADE7756AN	Plastic DIP	N-20
ADE7756BN	Plastic DIP	N-20
ADE7756ARS	Shrink Small Outline Package in Tubes	RS-20
ADE7756ARSRL	Shrink Small Outline Package in Tubes	RS-20
ADE7756BRS	Shrink Small Outline Package in Tubes	RS-20
ADE7756BRSRL	Shrink Small Outline Package in Reel	RS-20
EVAL-ADE7756EB	ADE7756 Evaluation Board	
ADE7756AN-REF	ADE7756 Reference Design	

PIN CONFIGURATION

DIP and SSOP Packages

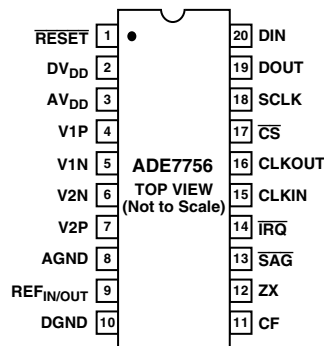

PIN FUNCTION DESCRIPTIONS

Pin No.	Mnemonic	Description
1	$\overline{\text{RESET}}$	Reset Pin for the ADE7756. A logic low on this pin will hold the ADCs and digital circuitry (including the Serial Interface) in a reset condition.
2	DV _{DD}	Digital Power Supply. This pin provides the supply voltage for the digital circuitry in the ADE7756. The supply voltage should be maintained at 5 V ± 5% for specified operation. This pin should be decoupled to DGND with a 10 μF capacitor in parallel with a ceramic 100 nF capacitor.
3	AV _{DD}	Analog Power Supply. This pin provides the supply voltage for the analog circuitry in the ADE7756. The supply should be maintained at 5 V ± 5% for specified operation. Every effort should be made to minimize power supply ripple and noise at this pin by the use of proper decoupling. The typical performance graphs in this data sheet show the power supply rejection performance. This pin should be decoupled to AGND with a 10 μF capacitor in parallel with a ceramic 100 nF capacitor.
4, 5	V1P, V1N	Analog Inputs for Channel 1. This channel is intended for use with the current transducer. These inputs are fully differential voltage inputs with maximum differential input signal levels of ±1 V, ±0.5 V and ±0.25 V, depending on the full-scale selection. See Analog Inputs section. Channel 1 also has a PGA with gain selections of 1, 2, 4, 8, or 16. The maximum signal level at these pins with respect to AGND is ±1 V. Both inputs have internal ESD protection circuitry and in addition an overvoltage of ±6 V can be sustained on these inputs without risk of permanent damage.
6, 7	V2N, V2P	Analog Inputs for Channel 2. This channel is intended for use with the voltage transducer. These inputs are fully differential voltage inputs with a maximum differential signal level of ±1 V. Channel 2 also has a PGA with gain selections of 1, 2, 4, 8, or 16. The maximum signal level at these pins with respect to AGND is ±1 V. Both inputs have internal ESD protection circuitry, and an overvoltage of ±6 V can be sustained on these inputs without risk of permanent damage.
8	AGND	This pin provides the ground reference for the analog circuitry in the ADE7756, i.e., ADCs and reference. This pin should be tied to the analog ground plane or the quietest ground reference in the system. This quiet ground reference should be used for all analog circuitry, e.g., antialiasing filters, current and voltage transducers, etc. In order to keep ground noise around the ADE7756 to a minimum, the quiet ground plane should only be connected to the digital ground plane at one point. It is acceptable to place the entire device on the analog ground plane—see Applications Information section.
9	REF _{IN/OUT}	This pin provides access to the on-chip voltage reference. The on-chip reference has a nominal value of 2.4 V ± 8% and a typical temperature coefficient of 20 ppm/°C. An external reference source may also be connected at this pin. In either case this pin should be decoupled to AGND with a 1 μF ceramic capacitor.
10	DGND	This provides the ground reference for the digital circuitry in the ADE7756, i.e., multiplier, filters, and digital-to-frequency converter. Because the digital return currents in the ADE7756 are small, it is acceptable to connect this pin to the analog ground plane of the system—see Applications Information section. However, high bus capacitance on the DOUT pin may result in noisy digital current which could affect performance.
11	CF	Calibration Frequency Logic Output. The CF logic output gives Active Power information. This output is intended to be used for operational and calibration purposes. The full-scale output frequency can be adjusted by writing to the CFDIV Register—see Energy To Frequency Conversion section.
12	ZX	Voltage Waveform (Channel 2) Zero Crossing Output. This output toggles logic high and low at the zero crossing of the differential signal on Channel 2—see Zero Crossing Detection section.
13	$\overline{\text{SAG}}$	This open drain logic output goes active low when either no zero crossings are detected or a low voltage threshold (Channel 2) is crossed for a specified duration. See Line Voltage Sag Detection section.
14	$\overline{\text{IRQ}}$	Interrupt Request Output. This is an active low open drain logic output. Maskable interrupts include: Active Energy Register roll-over, Active Energy Register at half level, and arrivals of new waveform samples—see Interrupts section.
15	CLKIN	Master clock for ADCs and digital signal processing. An external clock can be provided at this logic input. Alternatively, a parallel resonant AT crystal can be connected across CLKIN and CLKOUT to provide a clock source for the ADE7756. The clock frequency for specified operation is 3.579545 MHz. Ceramic load capacitors of between 22 pF and 33 pF should be used with the gate oscillator circuit. Refer to crystal manufacturers data sheet for load capacitance requirements.
16	CLKOUT	A crystal can be connected across this pin and CLKIN as described above to provide a clock source for the ADE7756. The CLKOUT pin can drive one CMOS load when either an external clock is supplied at CLKIN or a crystal is being used.

ADE7756

Pin No.	Mnemonic	Description
17	\overline{CS}	Chip Select. Part of the 4-Wire SPI Serial Interface. This active low logic input allows the ADE7756 to share the serial bus with several other devices—see Serial Interface section.
18	SCLK	Serial Clock Input for the Synchronous Serial Interface. All Serial data transfers are synchronized to this clock. See Serial Interface section. The SCLK has a Schmitt-trigger input for use with a clock source that has a slow edge transition time, e.g., opto-isolator outputs.
19	DOUT	Data Output for the Serial Interface. Data is shifted out at this pin on the rising edge of SCLK. This logic output is normally in a high impedance state unless it is driving data onto the serial data bus—see Serial Interface section.
20	DIN	Data Input for the Serial Interface. Data is shifted in at this pin on the falling edge of SCLK—see Serial Interface section.

TERMINOLOGY

MEASUREMENT ERROR

The error associated with the energy measurement made by the ADE7756 is defined by the following formula:

Percentage Error =

$$\left(\frac{\text{Energy Registered by ADE7756} - \text{True Energy}}{\text{True Energy}} \right) \times 100\%$$

PHASE ERROR BETWEEN CHANNELS

The HPF (High-Pass Filter) in Channel 1 has a phase lead response. To offset this phase response and equalize the phase response between channels, a phase correction network is also placed in Channel 1. The phase correction network ensures a phase match between Channel 1 (current) and Channel 2 (voltage) to within $\pm 0.1^\circ$ over a range of 45 Hz to 65 Hz and $\pm 0.2^\circ$ over a range 40 Hz to 1 kHz.

POWER SUPPLY REJECTION

This quantifies the ADE7756 measurement error as a percentage of reading when the power supplies are varied. For the ac PSR measurement, a reading at nominal supplies (5 V) is taken. A second reading is obtained with the same input signal levels when an ac (175 mV rms/120 Hz) signal is introduced onto the supplies. Any error introduced by this ac signal is expressed as a percentage of reading—see Measurement Error definition above.

For the dc PSR measurement, a reading at nominal supplies (5 V) is taken. A second reading is obtained with the same input signal levels when the supplies are varied $\pm 5\%$. Any error introduced is again expressed as a percentage of reading.

ADC OFFSET ERROR

This refers to the dc offset associated with the analog inputs to the ADCs. It means that with the analog inputs connected to AGND the ADCs still see a dc analog input signal. The magnitude of the offset depends on the gain and input range selection—see Typical Performance Characteristics. However, when HPF1 is switched on the offset is removed from Channel 1 (current) and the power calculation is not affected by this offset. The offsets may be removed by performing an offset calibration—see Analog Inputs section.

GAIN ERROR

The gain error in the ADE7756 ADCs is defined as the difference between the measured ADC output code (minus the offset) and the ideal output code—see Channel 1 ADC and Channel 2 ADC section. It is measured for each of the input ranges on Channel 1 (1 V, 0.5 V and 0.25 V). The difference is expressed as a percentage of the ideal code.

GAIN ERROR MATCH

The Gain Error Match is defined as the gain error (minus the offset) obtained when switching between a gain of 1 (for each of the input ranges) and a gain of 2, 4, 8, or 16. It is expressed as a percentage of the output ADC code obtained under a gain of 1. This gives the gain error observed when the gain selection is changed from 1 to 2, 4, 8, or 16.

Typical Performance Characteristics—ADE7756

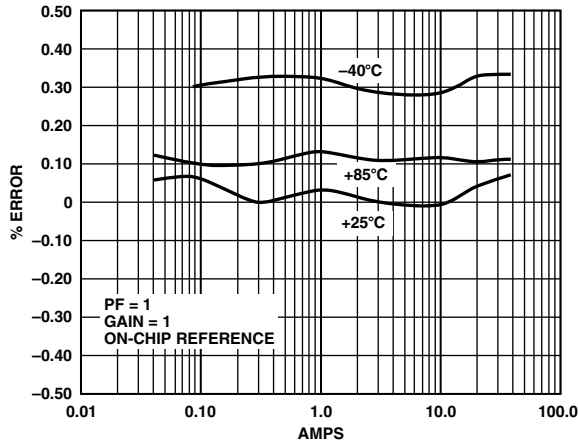

TPC 1. Error as a % of Reading (Power Factor = 1, Internal Reference, Gain = 1)

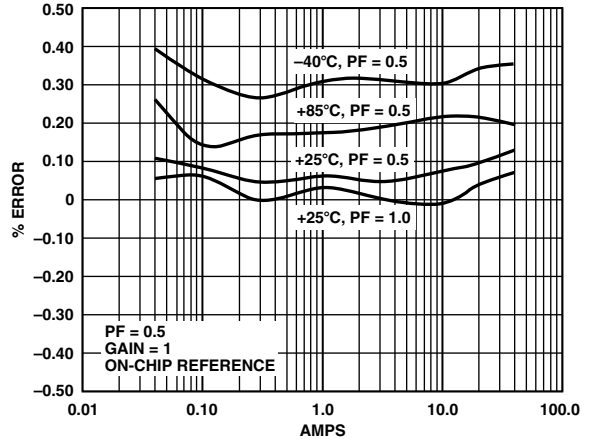

TPC 4. Error as a % of Reading (Power Factor = 0.5, Internal Reference, Gain = 1)

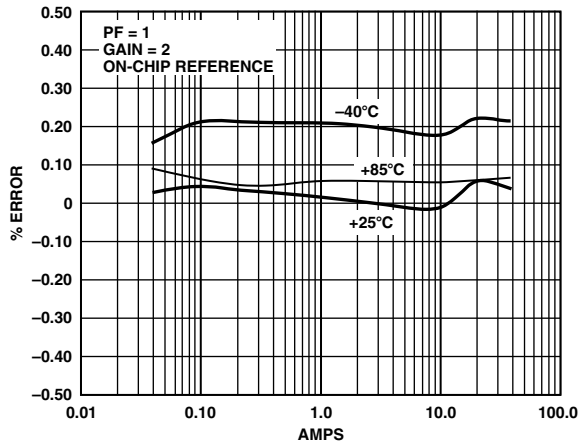

TPC 2. Error as a % of Reading (Power Factor = 1, Internal Reference, Gain = 2)

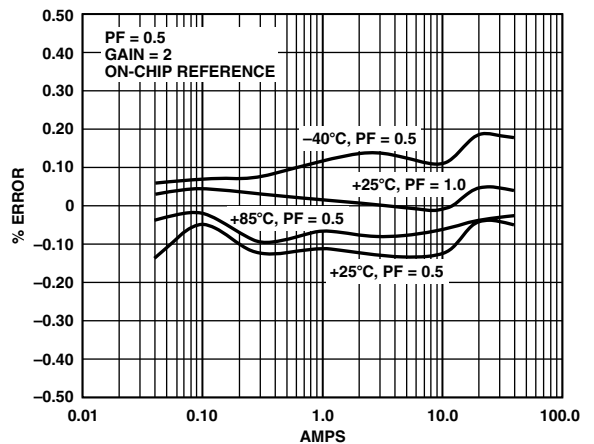

TPC 5. Error as a % of Reading (Power Factor = 0.5, Internal Reference, Gain = 2)

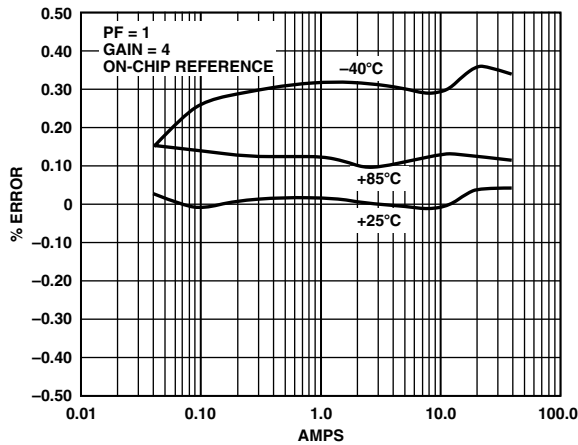

TPC 3. Error as a % of Reading (Power Factor = 1, Internal Reference, Gain = 4)

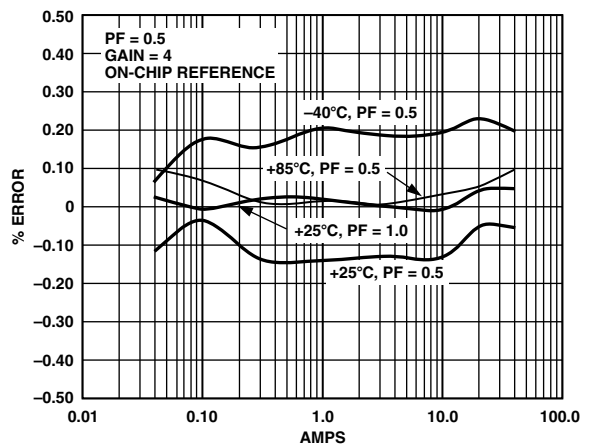

TPC 6. Error as a % of Reading (Power Factor = 0.5, Internal Reference, Gain = 4)

ADE7756

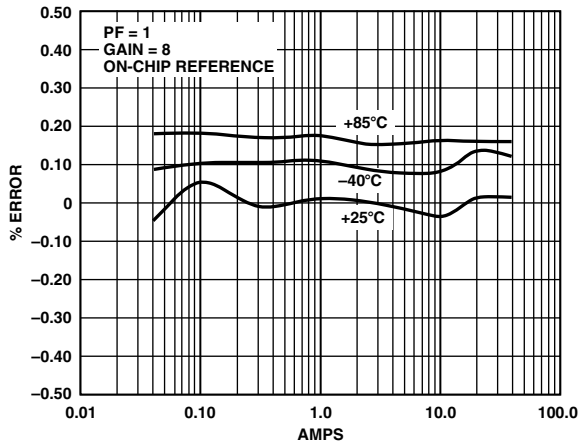

TPC 7. Error as a % of Reading (Power Factor = 1, Internal Reference, Gain = 8)

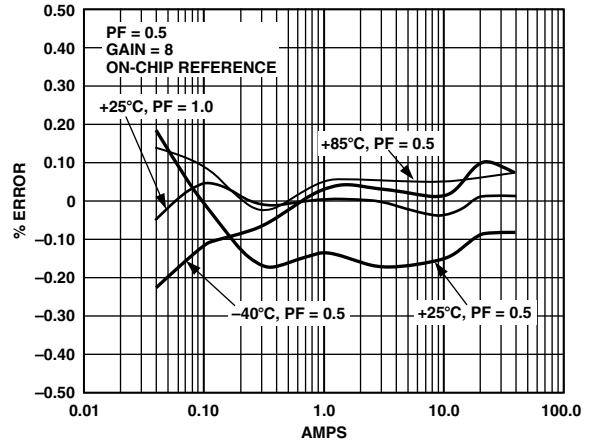

TPC 10. Error as a % of Reading (Power Factor = 0.5, Internal Reference, Gain = 8)

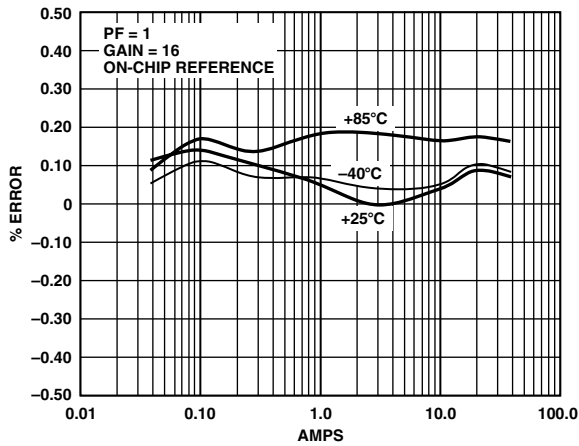

TPC 8. Error as a % of Reading (Power Factor = 1, Internal Reference, Gain = 16)

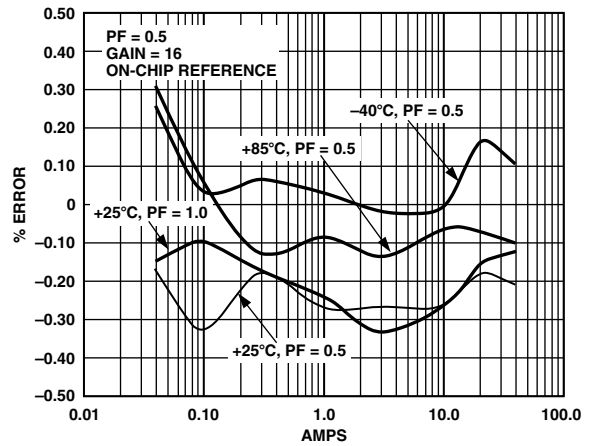

TPC 11. Error as a % of Reading (Power Factor = 0.5, Internal Reference, Gain = 16)

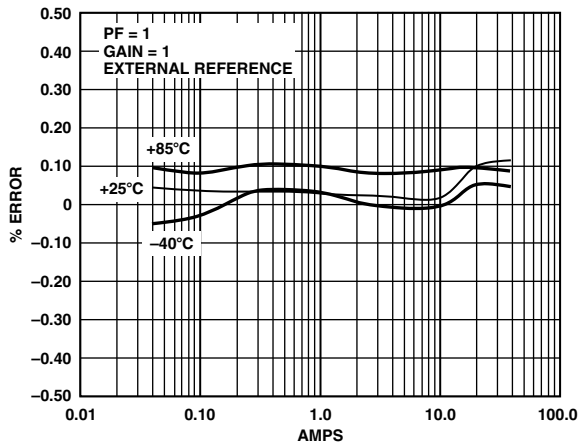

TPC 9. Error as a % of Reading (Power Factor = 1, External Reference, Gain = 1)

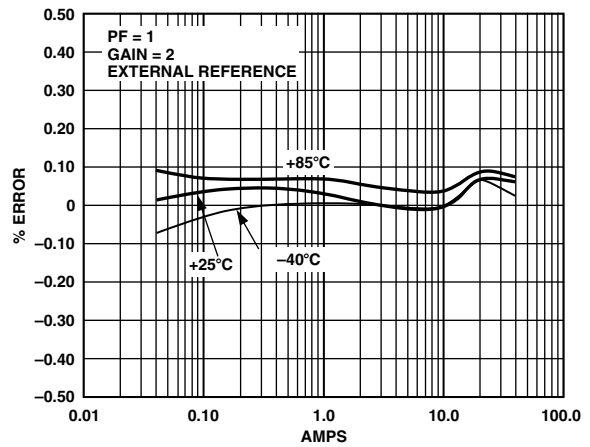

TPC 12. Error as a % of Reading (Power Factor = 1, External Reference, Gain = 2)

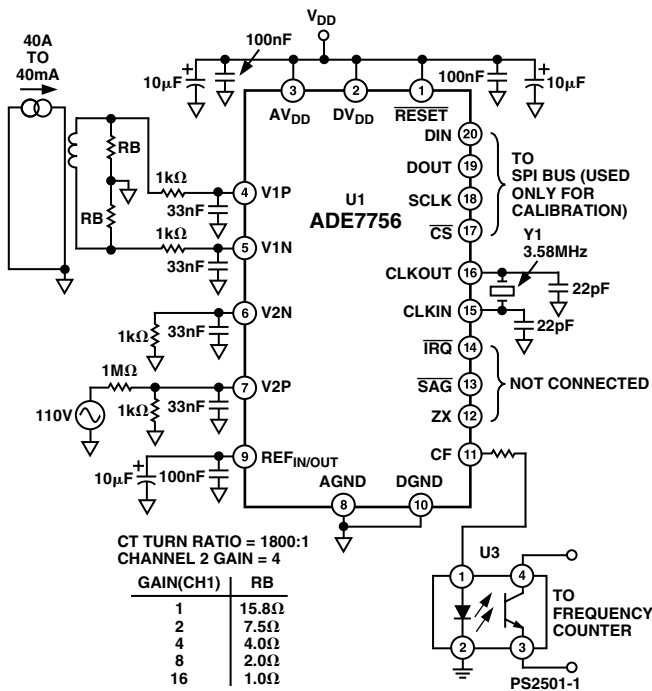

TPC 13. Test Circuit for Performance Curves

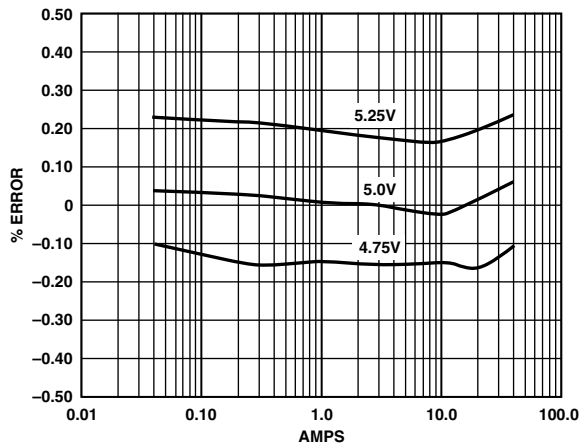

TPC 14. PSR with Internal Reference

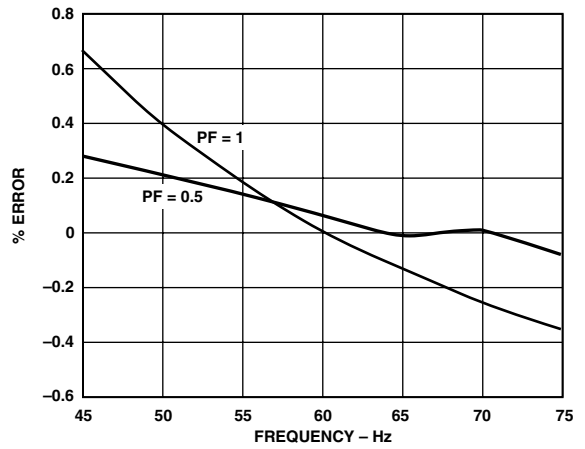

TPC 15. Error as a % of Reading over Frequency

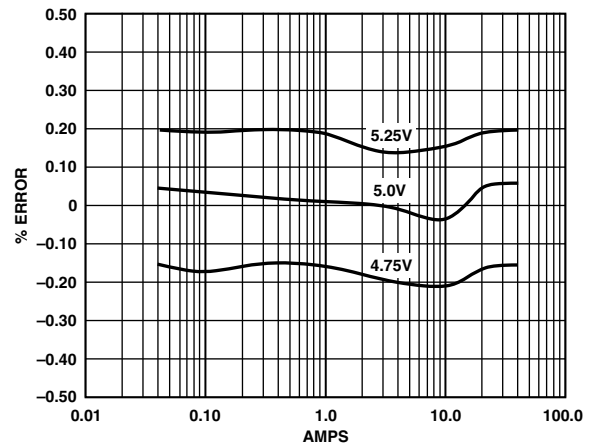

TPC 16. PSR with External Reference

ADE7756

ANALOG INPUTS

The ADE7756 has two fully differential voltage input channels. The maximum differential input voltage for each input pair (V1P/V1N and V2P/V2N) is ± 1 V. In addition, the maximum signal level on each analog input (V1P, V1N, V2P, and V2N) is also ± 1 V with respect to AGND.

Each analog input channel has a PGA (Programmable Gain Amplifier) with possible gain selections of 1, 2, 4, 8, and 16. The gain selections are made by writing to the Gain register—see Figure 5. Bits 0 to 2 select the gain for the PGA in Channel 1 and the gain selection for the PGA in Channel 2 is made via bits 5 to 7. Figure 4 shows how a gain selection for Channel 1 is made using the Gain register.

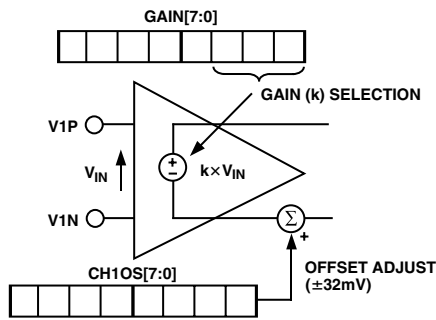

Figure 4. PGA in Channel 1

In addition to the PGA, Channel 1 also has a full-scale input range selection for the ADC. The ADC analog input range selection is also made using the Gain register—see Figure 5. As mentioned previously, the maximum differential input voltage is ± 1 V. However, by using Bits 3 and 4 in the Gain register, the maximum ADC input voltage can be set to 1 V, 0.5 V, or 0.25 V. This is achieved by adjusting the ADC reference—see Reference Circuit section. Table I summarizes the maximum differential input signal level on Channel 1 for the various ADC range and gain selections.

Table I. Maximum Input Signal Levels for Channel 1

Max Signal Channel 1	ADC Input Range Selection		
	1 V	0.5 V	0.25 V
1 V	Gain = 1		
0.5 V	Gain = 2	Gain = 1	
0.25 V	Gain = 4	Gain = 2	Gain = 1
0.125 V	Gain = 8	Gain = 4	Gain = 2
0.0625 V	Gain = 16	Gain = 8	Gain = 4
0.0313 V		Gain = 16	Gain = 8
0.0156 V			Gain = 16

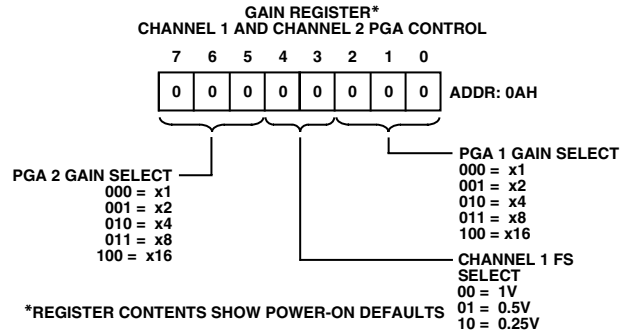

Figure 5. Analog Gain Register

It is also possible to adjust offset errors on Channel 1 and Channel 2 by writing to the Offset Correction Registers (CH1OS and CH2OS respectively). These registers allow channel offsets in the range ± 20 mV to ± 60 mV (depending on the gain setting) to be removed. Note that it is not necessary to perform an offset correction in an Energy measurement application if HPF1 in Channel 1 is switched on. Figure 6 shows the effect of offsets on the real power calculation. As can be seen from Figure 6, an offset on Channel 1 and Channel 2 will contribute a dc component after multiplication. Since this dc component is extracted by LPF2 to generate the Active (Real) Power information, the offsets will have contributed an error to the Active Power calculation. This problem is easily avoided by enabling HPF1 in Channel 1. By removing the offset from at least one channel, no error component can be generated at dc by the multiplication. Error terms at $\cos(\omega t)$ are removed by LPF2 and by integration of the Active Power signal in the Active Energy register (AENERGY[39:0]). See Energy Calculation section.

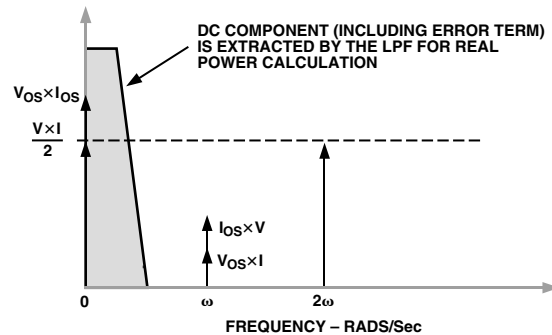

Figure 6. Effect of Channel Offsets on the Real Power Calculation

The contents of the Offset Correction registers are 6-bit, sign and magnitude coded. The weighting of the LSB size depends on the gain setting, i.e., 1, 2, 4, 8, or 16. Table II below shows the correctable offset span for each of the gain settings and the LSB weight (mV) for the Offset Correction registers. The maximum value that can be written to the Offset Correction registers is ± 31 decimal—see Figure 7.

Table II. Offset Correction Range

Gain	Correctable Span	LSB Size
1	± 60 mV	1.88 mV/LSB
2	± 40 mV	1.25 mV/LSB
4	± 25 mV	0.78 mV/LSB
8	± 23 mV	0.72 mV/LSB
16	± 20 mV	0.63 mV/LSB

Figure 7 shows the relationship between the Offset Correction register contents and the offset (mV) on the analog inputs for a gain setting of one. In order to perform an offset adjustment, The analog inputs should be first connected to AGND. There should be no signal on either Channel 1 or Channel 2. A read from Channel 1 or Channel 2 using the waveform register will give an indication of the offset in the channel. This offset can be canceled by writing an equal and opposite offset value to the relevant offset register. The offset correction can be confirmed by performing another read. Note when adjusting the offset of Channel 1, one needs to ensure the HPF has been disabled in the Mode Register.

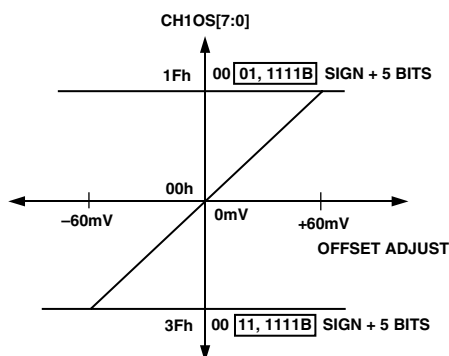

Figure 7. Channel Offset Correction Range (Gain = 1)

ZERO CROSSING DETECTION

The ADE7756 has a zero crossing detection circuit on Channel 2. This zero crossing is used to produce an external zero cross signal (ZX) and it is also used in the calibration mode—see Energy Calibration section. The zero crossing signal is also used to initiate a temperature measurement on the ADE7756—see Temperature Measurement section.

Figure 8 shows how the zero cross signal is generated from the output of LPF1.

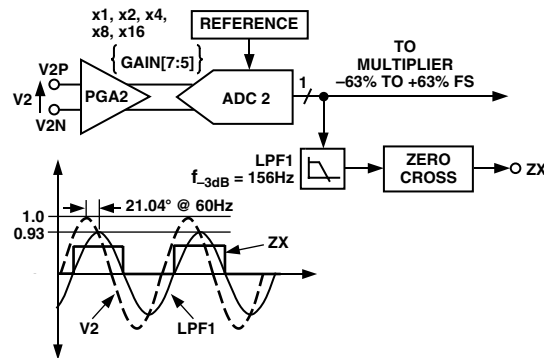

Figure 8. Zero Cross Detection on Channel 2

The ZX signal will go logic high on a positive going zero crossing and logic low on a negative going zero crossing on Channel 2. The zero crossing signal ZX is generated from the output of LPF1. LPF1 has a single pole at 156 Hz (at CLKIN = 3.579545 MHz). As a result there will be a phase lag between the analog input signal V2 and the output of LPF1. The phase response of this filter is shown in the Channel 2 Sampling section of this data sheet. The phase lag response of LPF1 results in a time delay of approximately 0.97 ms (@ 60 Hz) between the zero crossing on the analog inputs of Channel 2 and the rising or falling edge of ZX.

The zero crossing detection also has an associated time-out register ZXTOUT. This unsigned, 12-bit register is decremented (1 LSB) every 128/CLKIN seconds. The register is reset to its user-programmed full-scale value every time a zero crossing on Channel 2 is detected. The default power-on value in this register is FFFh. If the register decrements to zero before a zero crossing is detected, and the DISSAG bit in the Mode register is Logic 0, the SAG pin will go active low. The absence of a zero crossing is also indicated on the IRQ output if the SAG enable bit in the Interrupt Enable register is set to Logic 1. Irrespective of the enable bit setting, the SAG flag in the Interrupt Status register is always set when the ZXTOUT register is decremented to zero—see ADE7756 Interrupts section.

The Zero-Cross Time-Out register can be written/read by the user and has an address of 0Eh—see Serial Interface section. The resolution of the register is 128/CLKIN seconds per LSB. Thus the maximum delay for an interrupt is 0.15 second (128/CLKIN $\times 2^{12}$).

ADE7756

LINE VOLTAGE SAG DETECTION

In addition to the detection of the loss of the line voltage signal (zero crossing), the ADE7756 can also be programmed to detect when the absolute value of the line voltage drops below a certain peak value, for a number of half-cycles. This condition is illustrated in Figure 9.

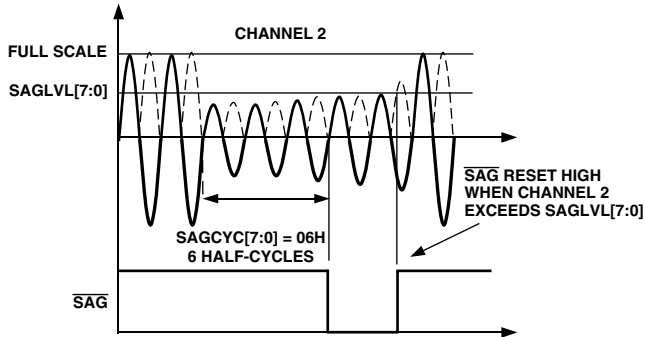

Figure 9. ADE7756 Sag Detection

Figure 9 shows the line voltage fall below a threshold that is set in the Sag Level register (SAGLVL[7:0]) for nine half-cycles. Since the Sag Cycle register (SAGCYC[7:0]) contains 06h, the $\overline{\text{SAG}}$ pin will go active low at the end of the sixth half-cycle for which the line voltage falls below the threshold, if the DISSAG bit in the Mode register is Logic 0. As is the case when zero-crossings are no longer detected, the sag event is also recorded by setting the SAG flag in the Interrupt Status register. If the SAG enable bit is set to Logic 1, the $\overline{\text{IRQ}}$ logic output will go active low—see ADE7756 Interrupts section.

The $\overline{\text{SAG}}$ pin will go logic high again when the absolute value of the signal on Channel 2 exceeds the sag level set in the Sag Level register. This is shown in Figure 9 when the $\overline{\text{SAG}}$ pin goes high during the tenth half-cycle from the time when the signal on Channel 2 first dropped below the threshold level.

Sag Level Set

The contents of the Sag Level register (1 byte) are compared to the absolute value of the most significant byte output from LPF1, after it is shifted left by one bit. Thus for example the nominal maximum code from LPF1 with a full scale signal on Channel 2 is 1C396h or (0001, 1100, 0011, 1001, 0110b)—see Channel 2 Sampling section. Shifting one bit left will give 0011,

1000, 0111, 0010, 1100b or 3872Ch. Therefore writing 38h to the Sag Level register will put the sag detection level at full scale. Writing 00h will put the sag detection level at zero. The Sag Level register is compared to the most significant byte of a waveform sample after the shift left and detection is made when the contents of the sag level register are greater.

POWER SUPPLY MONITOR

The ADE7756 also contains an on-chip power supply monitor. The Analog Supply (AV_{DD}) is continuously monitored by the ADE7756. If the supply is less than $4\text{ V} \pm 5\%$, the ADE7756 will be inactive, i.e., no energy will accumulate regardless of the input signals at Channel 1 and Channel 2. This is useful to ensure correct device operation at power-up and during power-down. The power supply monitor has built-in hysteresis and filtering. This gives a high degree of immunity to false triggering due to noisy supplies.

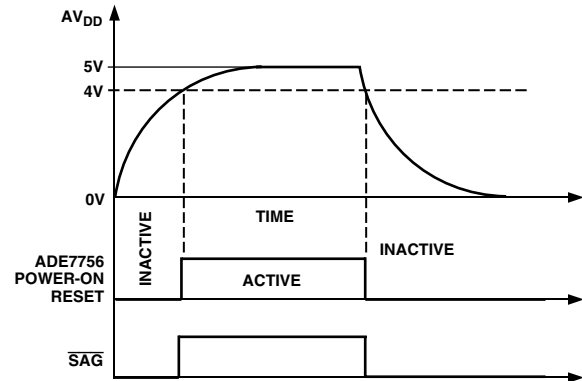

Figure 10. On-Chip Power Supply Monitor

As can be seen from Figure 10, the trigger level is nominally set at 4 V. The tolerance on this trigger level is about $\pm 5\%$. The $\overline{\text{SAG}}$ pin can also be used as a power supply monitor input to the MCU. The $\overline{\text{SAG}}$ pin will go logic low when the ADE7756 is reset. The power supply and decoupling for the part should be such that the ripple at AV_{DD} does not exceed $5\text{ V} \pm 5\%$ as specified for normal operation.

INTERRUPTS

Interrupts are managed through the Interrupt Status register (STATUS[7:0]) and the Interrupt Enable register (IRQEN[7:0]). When an interrupt event occurs in the ADE7756, the corresponding flag in the Status register is set to a Logic 1—see Interrupt Status register. If the enable bit for this interrupt in the Interrupt Enable register is Logic 1, the $\overline{\text{IRQ}}$ logic output goes active low. The flag bits in the Status register are set irrespective of the state of the enable bits.

In order to determine the source of the interrupt, the system master (MCU) should perform a read from the Status register with reset (RSTATUS[7:0]). This is achieved by carrying out a read from address 05h. The $\overline{\text{IRQ}}$ output will go logic high on completion of the Interrupt Status register read command—see Interrupt Timing section. When carrying out a read with reset the ADE7756 is designed to ensure that no interrupt events are missed. If an interrupt event occurs just as the Status register is being read, the event will not be lost and the $\overline{\text{IRQ}}$ logic output is guaranteed to go high for the duration of the Interrupt Status register data transfer before going logic low again to indicate the pending interrupt. See the next section for a more detailed description.

Using the ADE7756 Interrupts with an MCU

Shown in Figure 11 is a timing diagram that shows a suggested implementation of ADE7756 interrupt management using an MCU. At time t_1 the $\overline{\text{IRQ}}$ line will go active low indicating that one or more interrupt events have occurred in the ADE7756. The $\overline{\text{IRQ}}$ logic output should be tied to a negative edge-triggered external interrupt on the MCU. On detection of

the negative edge, the MCU should be configured to start executing its Interrupt Service Routine (ISR). On entering the ISR, all interrupts should be disabled using the global interrupt enable bit. At this point the MCU external interrupt flag can be cleared in order to capture interrupt events that occur during the current ISR. When the MCU interrupt flag is cleared a read from the Status register with reset is carried out. This will cause the $\overline{\text{IRQ}}$ line to be reset logic high (t_2)—see Interrupt timing section. The Status register contents are used to determine the source of the interrupt(s) and hence the appropriate action to be taken. If a subsequent interrupt event occurs during the ISR, that event will be recorded by the MCU external interrupt flag being set again (t_3). On returning from the ISR, the global interrupt mask will be cleared (same instruction cycle) and the external interrupt flag will cause the MCU to jump to its ISR once again. This will ensure that the MCU does not miss any external interrupts.

Interrupt Timing

The Serial Interface section should be reviewed first, before reviewing the interrupt timing. As previously described, when the $\overline{\text{IRQ}}$ output goes low the MCU ISR must read the Interrupt Status register in order to determine the source of the interrupt. When reading the Status register contents, the $\overline{\text{IRQ}}$ output is set high on the last falling edge of SCLK of the first byte transfer (read Interrupt Status register command). The $\overline{\text{IRQ}}$ output is held high until the last bit of the next 8-bit transfer (Interrupt Status register contents). See Figure 12. If an interrupt is pending at this time, the $\overline{\text{IRQ}}$ output will go low again. If no interrupt is pending the $\overline{\text{IRQ}}$ output will stay high.

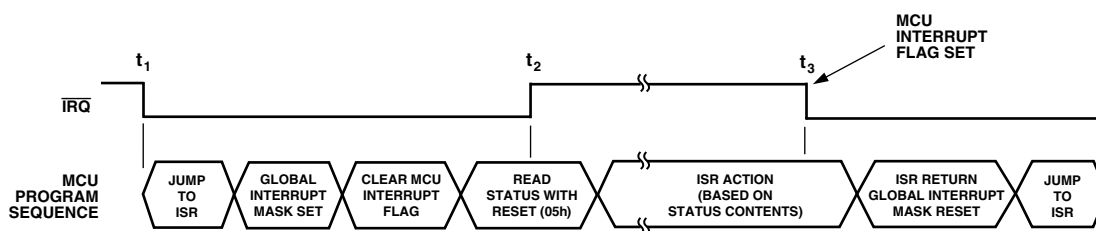

Figure 11. Interrupt Management

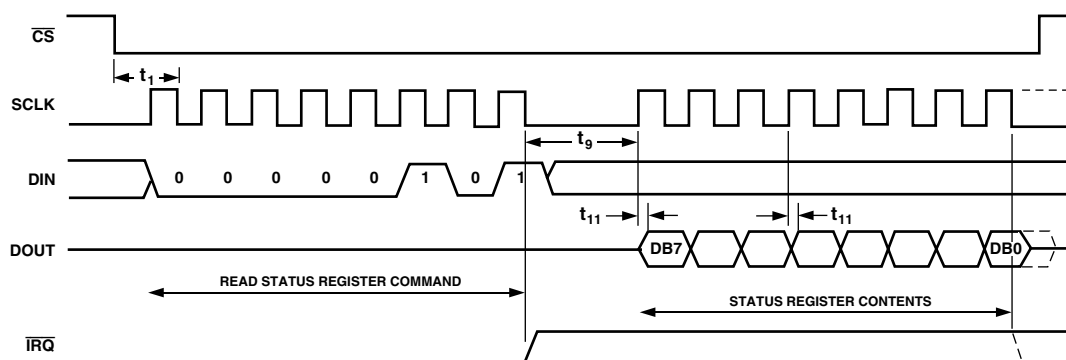

Figure 12. Interrupt Timing

ADE7756

TEMPERATURE MEASUREMENT

ADE7756 also includes an on-chip temperature sensor. A temperature measurement can be made by setting Bit 5 in the Mode register. When Bit 5 is set logic high in the Mode register, the ADE7756 will initiate a temperature measurement on the next zero crossing. When the zero crossing on Channel 2 is detected, the voltage output from the temperature sensing circuit is connected to ADC1 (Channel 1) for digitizing. The resultant code is processed and placed in the Temperature register (TEMP[7:0]) approximately 26 μ s later (24 CLKIN cycles). If enabled in the Interrupt Enable register (Bit 5), the $\overline{\text{IRQ}}$ output will go active low when the temperature conversion is finished. Please note that temperature conversion will introduce a small amount of noise in the energy calculation. If temperature conversion is performed frequently (e.g., multiple times per second), a noticeable error will accumulate in the resulting energy calculation over time.

The contents of the Temperature register are signed (two's complement) with a resolution of approximately 1 LSB/ $^{\circ}$ C. The temperature register will produce a code of 00h when the ambient temperature is approximately 70 $^{\circ}$ C—see Figure 13. The temperature measurement is uncalibrated in the ADE7756 and has an offset tolerance that could be as high as $\pm 20^{\circ}$ C.

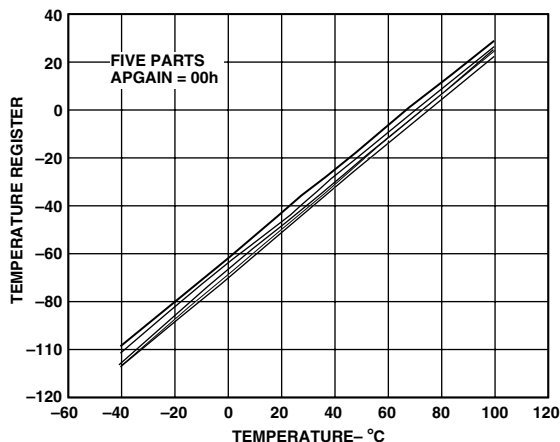

Figure 13. Temperature Register

ANALOG-TO-DIGITAL CONVERSION

The analog-to-digital conversion in the ADE7756 is carried out using two second-order sigma-delta ADCs. The block diagram in Figure 14 shows a first-order (for simplicity) sigma-delta ADC. The converter is made up of two parts, first the sigma-delta modulator and second the digital low-pass filter.

A sigma-delta modulator converts the input signal into a continuous serial stream of 1s and 0s at a rate determined by the sampling clock. In the ADE7756 the sampling clock is equal to CLKIN/4. The 1-bit DAC in the feedback loop is driven by the serial data stream. The DAC output is subtracted from the input signal. If the loop gain is high enough, the average value of the DAC output (and therefore the bit stream) will approach that of the input signal level. For any given input value in a single

sampling interval, the data from the 1-bit ADC is virtually meaningless. Only when a large number of samples are averaged, will a meaningful result be obtained. This averaging is carried out in the second part of the ADC, the digital low-pass filter. By averaging a large number of bits from the modulator the low-pass filter can produce 20-bit data words that are proportional to the input signal level.

The sigma-delta converter uses two techniques to achieve high resolution from what is essentially a 1-bit conversion technique. The first is oversampling. By oversampling we mean that the signal is sampled at a rate (frequency) that is many times higher than the bandwidth of interest. For example, the sampling rate in the ADE7756 is CLKIN/4 (894 kHz) and the band of interest is 40 Hz to 2 kHz. Oversampling has the effect of spreading the quantization noise (noise due to sampling) over a wider bandwidth. With the noise spread more thinly over a wider bandwidth, the quantization noise in the band of interest is lowered—see Figure 15. However oversampling alone is not an efficient enough method to improve the signal to noise ratio (SNR) in the band of interest. For example, an oversampling ratio of 4 is required just to increase the SNR by only 6 dB (1 bit). To keep the oversampling ratio at a reasonable level, it is possible to shape the quantization noise so that the majority of the noise lies at the higher frequencies. This is what happens in the sigma-delta modulator, the noise is shaped by the integrator which has a high-pass-type response for the quantization noise. The result is that most of the noise is at the higher frequencies where it can be removed by the digital low-pass filter. This noise shaping is also shown in Figure 15.

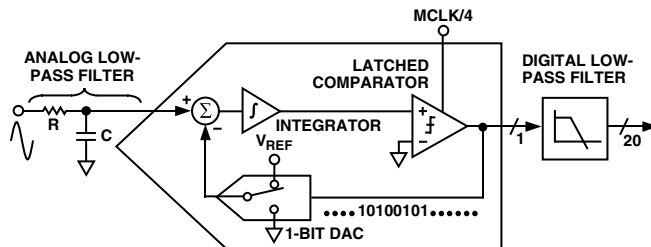

Figure 14. First Order Sigma-Delta (Σ - Δ) ADC

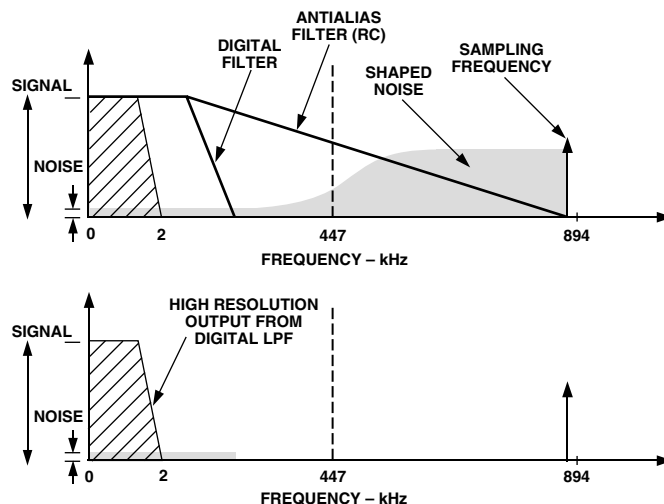

Figure 15. Noise Reduction Due to Oversampling and Noise Shaping in the Analog Modulator

Antialias Filter

Figure 21 also shows an analog low-pass filter (RC) on the input to the modulator. This filter is present to prevent aliasing. Aliasing is an artifact of all sampled systems.

Figure 16 illustrates the effect, frequency components (arrows shown in black) above half the sampling frequency (also known as the Nyquist frequency, i.e., 447 kHz) is imaged or folded back down below 447 kHz (arrows shown in grey). This will happen with all ADCs no matter what the architecture is. In the example shown it can be seen that only frequencies near the sampling frequency, i.e., 894 kHz, will move into the band of interest for metering, i.e., 40 Hz–2 kHz. This fact will allow us to use a very simple LPF (Low-Pass Filter) to attenuate these high frequencies (near 900 kHz) and so prevent distortion in the band of interest. A simple RC filter (single-pole) with a corner frequency of 10 kHz will produce an attenuation of approximately 40 dBs at 894 kHz—see Figure 15. This is sufficient to eliminate the effects of aliasing.

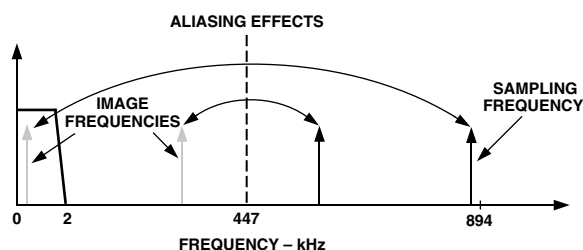

Figure 16. ADC and Signal Processing in Channel 1

ADC Transfer Function

Below is an expression that relates the output of the LPF in the sigma-delta ADC to the analog input signal level. Both ADCs in the ADE7756 are designed to produce the same output code for the same input signal level.

$$\text{Code (ADC)} = 1.512 \times \frac{V_{IN}}{V_{REF}} \times 262,144$$

Therefore, with a full-scale signal on the input of 1 V, and an internal reference of 2.4 V, the ADC output code is nominally 165,151 or 2851Fh. The maximum code from the ADC is $\pm 262,144$, which is equivalent to an input signal level of ± 1.6 V. However, for specified performance it is not recommended that the full-scale input signal level of ± 1 V be exceeded.

Reference Circuit

Shown in Figure 17 is a simplified version of the reference output circuitry. The nominal reference voltage at the REF_{IN/OUT} pin is 2.42 V. This is the reference voltage used for the ADCs in the ADE7756. However, Channel 1 has three input range selections that are selected by dividing down the reference value used for the ADC in Channel 1. The reference value used for Channel 1 is divided down to 1/2 and 1/4 of the nominal value by using an internal resistor divider as shown in Figure 17.

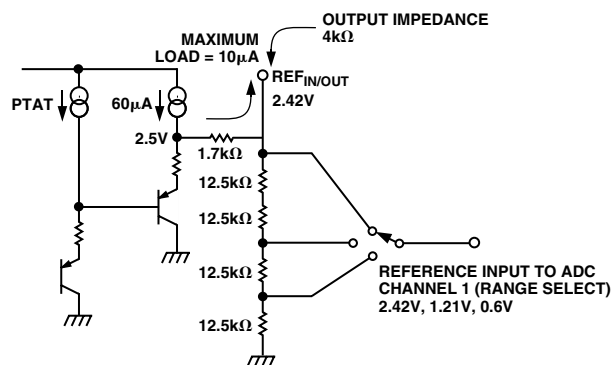

Figure 17. Reference Circuit Output

The REF_{IN/OUT} pin can be overdriven by an external source, e.g., an external 2.5 V reference. Note that the nominal reference value supplied to the ADCs is now 2.5 V, not 2.42 V. This has the effect of increasing the nominal analog input signal range by $2.5/2.42 \times 100\% = 3\%$, or from 1 V to 1.03 V.

The voltage of ADE7756 reference drifts slightly with temperature—see ADE7756 Specifications for the temperature coefficient specification (in ppm/°C). The value of the temperature drift varies from part to part. On A-grade parts, the maximum temperature drift is not guaranteed. Since the reference is used for the ADCs in both Channel 1 and 2, any x% drift in the reference will result in 2x% deviation of the meter accuracy. The reference drift resulting from temperature changes is usually very small and it is typically much smaller than the drift of other components on a meter. However, if guaranteed temperature performance is needed, one needs to use an external voltage reference or to use B-grade parts. Alternatively, the meter can be calibrated at multiple temperatures. Real-time compensation can be easily achieved using the on the on-chip temperature sensor.

ADE7756

CHANNEL 1 ADC

Figure 18 shows the ADC and signal processing chain for Channel 1. In waveform sampling mode the ADC outputs a signed two's complement 20-bit data word at a maximum of 27.9 kSPS (CLKIN/128). The output of the ADC can be scaled by $\pm 50\%$ to perform an overall power calibration or to calibrate the ADC output. While the ADC outputs a 20-bit two's complement value, the maximum full-scale positive value from the ADC is limited to 40000h (+262,144 decimal). The maximum full-scale negative value is limited to C0000h (-262,144 Decimal). If the analog inputs are overranged, the ADC output code will clamp at these values. With the specified full scale analog input signal of 1 V (or 0.5 V or 0.25 V—see Analog Inputs section) the ADC will produce an output code which is approximately 63% of its full-scale value. This is illustrated in Figure 18. The diagram in Figure 15 shows a full-scale voltage signal being applied to the differential inputs V1P and V1N. The ADC output swings between D7AE1h (-165,151) and 2851Fh (+165,151). This is approximately 63% of the full-scale value 40000h (262,144). Overranging the analog inputs with more than 1 V differential (0.5 or 0.25, depending on Channel 1 full-scale selection) will cause the ADC output to increase towards its full-scale value. However for specified operation the differential signal on the analog inputs should not exceed the recommended value of 1.0 V.

Channel 1 ADC Gain Adjust

The ADC gain in Channel 1 can be adjusted by using the multiplier and Active Power Gain register (APGAIN[11:0]). The gain of the ADC is adjusted by writing a two's complement 12-bit word to the Active Power Gain register. Following is

the expression that shows how the gain adjustment is related to the contents of the Active Power Gain register.

$$Code = \left(ADC \times \left\{ 1 + \frac{APGAIN}{2^{12}} \right\} \right)$$

For example when 7FFh is written to the Active Power Gain register the ADC output is scaled up by 50%. 7FFh = 2047 decimal, $2047/2^{12} = 0.5$. Similarly, 801h = -2047 decimal (signed two's complement) and ADC output is scaled by -50%. These two examples are graphically illustrated in Figure 18.

Channel 1 Sampling

The waveform samples may also be routed to the Waveform register (MODE[14:13] = 1, 0) to be read by the system master (MCU). In waveform sampling mode the WSMP bit (Bit 3) in the Interrupt Enable register must also be set to Logic 1. The Active Power and Energy calculation will remain uninterrupted during waveform sampling.

When in waveform sample mode, one of four output sample rates may be chosen by using Bits 11 and 12 of the Mode register (WAVSEL1, 0). The output sample rate may be 27.9 kSPS, 14 kSPS, 7 kSPS or 3.5 kSPS—see Mode Register section. The interrupt request output \overline{IRQ} signals a new sample availability by going active low. The timing is shown in Figure 19. The 20-bit waveform samples are transferred from the ADE7756 one byte (8 bits) at a time, with the most significant byte shifted out first. The 20-bit data word is right-justified and sign extended to 24 bits (three bytes)—see Serial Interface section.

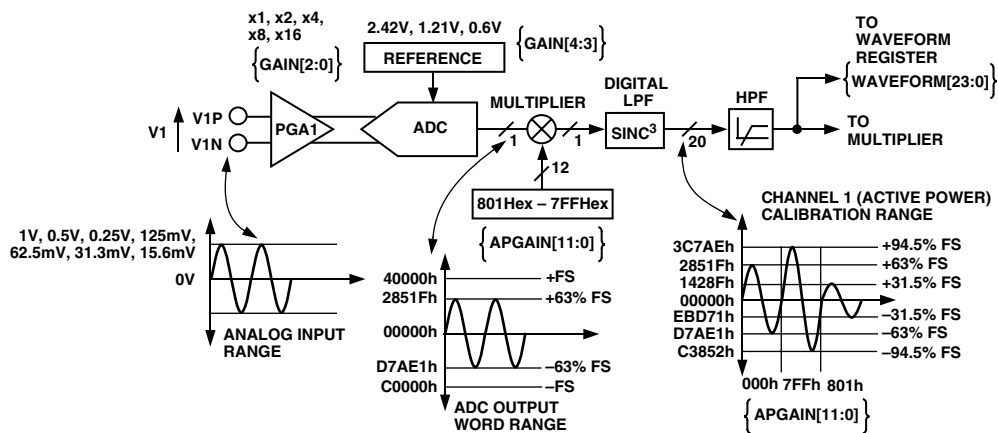

Figure 18. ADC and Signal Processing in Channel 1

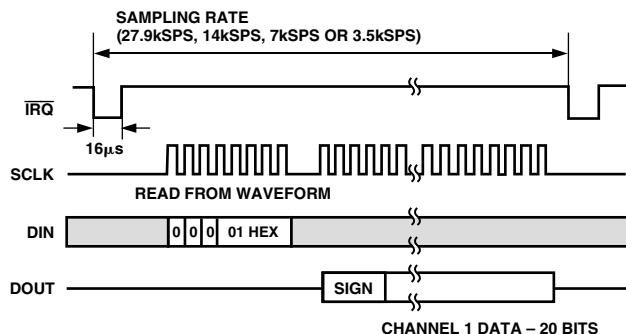

Figure 19. Waveform Sampling Channel 1

CHANNEL 2 ADC

Channel 2 Sampling

In Channel 2 waveform sampling mode (MODE[14:13] = 1, 1 and WSMP = 1) the ADC output code scaling for Channel 2 is the same as Channel 1, i.e., the output swings between D7AE1h (-165,151) and 2851Fh (+165,151)—see ADC Channel 1 section. However, before being passed to the Waveform register, the ADC output is passed through a single-pole, low-pass filter with a cutoff frequency of 156 Hz. The plots in Figure 20 shows the magnitude and phase response of this filter.

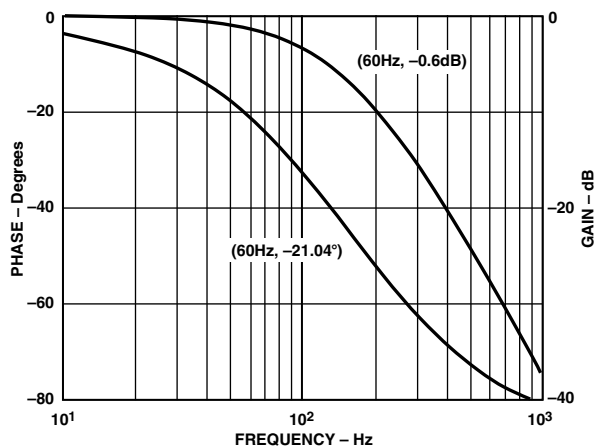

Figure 20. Magnitude and Phase Response of LPF1

This has the effect of attenuating the signal. For example, if the line frequency is 60 Hz, the signal at the output of LPF1 will be attenuated by 30%.

$$|H(f)| = \frac{1}{\sqrt{1 + \left(\frac{60 \text{ Hz}}{156 \text{ Hz}}\right)^2}} = 0.93 = -0.6 \text{ dB}$$

Note that LPF1 does not affect the power calculation. The signal processing chain in Channel 2 is illustrated in Figure 21. Unlike Channel 1, Channel 2 has only one analog input range (1 V differential). However, like Channel 1, Channel 2 does have a PGA with gain selections of 1, 2, 4, 8, and 16. For energy measurement, the output of the ADC is passed directly to the multiplier and is not filtered. An HPF is not required to remove any dc offset since it is only required to remove the offset from one channel to eliminate errors due to offsets in the power calculation. When in waveform sample mode, one of four output sample rates can be chosen by using Bits 11 and 12 of the Mode register. The available output sample rates are 27.9 kSPS, 14 kSPS, 7 kSPS or 3.5 kSPS—see Mode Register section. The interrupt request output $\overline{\text{IRQ}}$ signals a new sample availability by going active low. The timing is the same as that for Channel 1 and is shown in Figure 19.

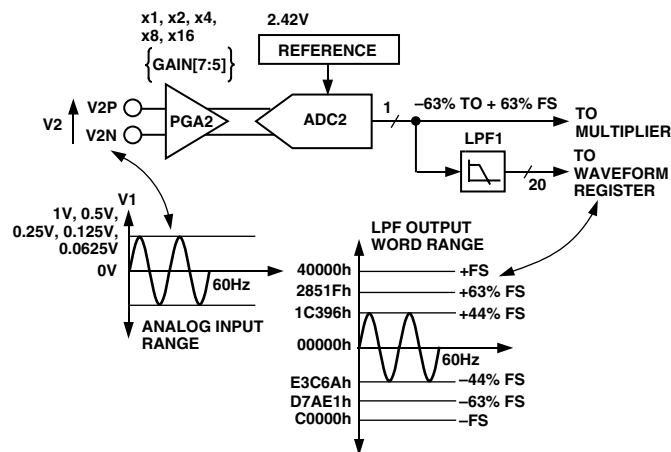

Figure 21. ADC and Signal Processing in Channel 2

ADE7756

PHASE COMPENSATION

When the HPF is disabled, the phase error between Channel 1 and Channel 2 is zero from dc to 3.5 kHz. When HPF1 is enabled, Channel 1 has a phase response illustrated in Figures 23 and 24. Also shown in Figure 25 is the magnitude response of the filter. As can be seen from the plots, the phase response is almost zero from 45 Hz to 1 kHz. This is all that is required in typical energy measurement applications.

However, despite being internally phase compensated the ADE7756 must work with transducers that may have inherent phase errors. For example, a phase error of 0.1° to 0.3° is not uncommon for a CT (Current Transformer). These phase errors can vary from part to part and must be corrected in order to perform accurate power calculations. The errors associated with phase mismatch are particularly noticeable at low power factors. The ADE7756 provides a means of digitally calibrating these small phase errors. The ADE7756 allows a small time delay or time advance to be introduced into the signal processing chain in order to compensate for small phase errors. Because the compensation is in time, this technique should only be used for small phase errors in the range of 0.1° to 0.5° . Correcting large phase errors using a time shift technique can introduce significant phase errors at higher harmonics.

The Phase Calibration register (PHCAL[5:0]) is a two's complement 6-bit signed register that can vary the time delay in the Channel 2 signal path from $-143 \mu\text{s}$ to $+143 \mu\text{s}$ ($\text{CLKIN} = 3.579545 \text{ MHz}$). One LSB is equivalent to $4.47 \mu\text{s}$. With a line frequency of 60 Hz, this gives a phase resolution of 0.097° at the fundamental (i.e., $360^\circ \times 4.47 \mu\text{s} \times 60 \text{ Hz}$). Figure 22 illustrates how the phase compensation is used to remove a 0.097° phase lead in Channel 1 due to some external transducer. In order to cancel the lead (0.097°) in Channel 1, a phase lead must also be introduced into Channel 2. The resolution of the phase adjustment allows the introduction of a phase lead of 0.097° . The phase lead is achieved by introducing a time advance into Channel 2. A time advance of $4.47 \mu\text{s}$ is made by writing -1 (3Fh) to the time delay block, thus reducing the amount of time delay by $4.47 \mu\text{s}$.

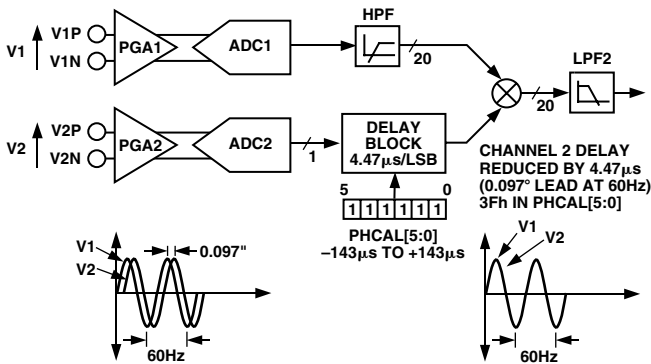

Figure 22. Phase Calibration

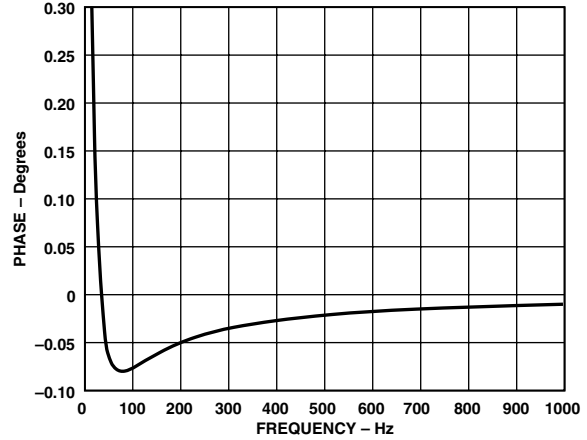

Figure 23. Combined Phase Response of the HPF and Phase Compensation (10 Hz to 1 kHz)

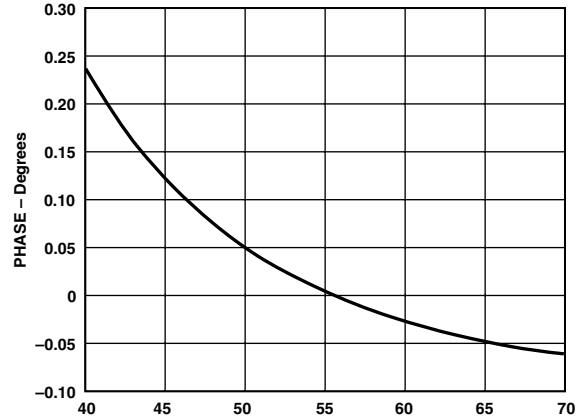

Figure 24. Combined Phase Response of the HPF and Phase Compensation (40 Hz to 70 Hz)

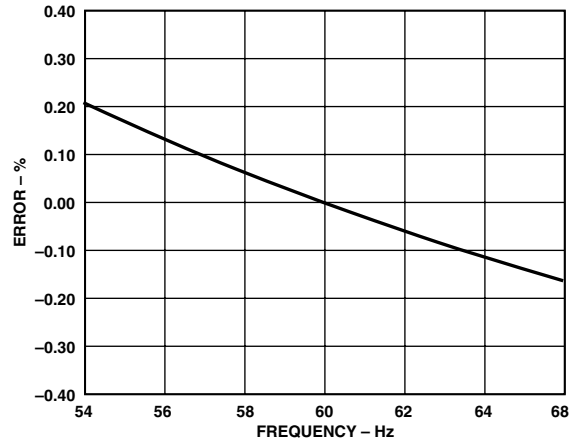

Figure 25. Combined Phase Response of the HPF and Phase Compensation (Deviation of Gain in % from Gain at 60 Hz)

ACTIVE POWER CALCULATION

Electrical power is defined as the rate of energy flow from source to load. It is given by the product of the voltage and current waveforms. The resulting waveform is called the instantaneous power signal and it is equal to the rate of energy flow at every instant of time. The unit of power is the watt or joules/sec. Equation 3 gives an expression for the instantaneous power signal in an ac system.

$$v(t) = \sqrt{2} V \sin(\omega t) \tag{1}$$

$$i(t) = \sqrt{2} I \sin(\omega t) \tag{2}$$

where

V = rms voltage,

I = rms current.

$$p(t) = v(t) \times i(t) \tag{3}$$

$$p(t) = VI - VI \cos(2\omega t) \tag{3}$$

The average power over an integral number of line cycles (n) is given by the expression in Equation 4.

$$P = \frac{1}{nT} \int_0^{nT} p(t) dt = VI \tag{4}$$

where

T is the line cycle period.

and

P is referred to as the Active or Real Power.

Note that the active power is equal to the dc component of the instantaneous power signal $p(t)$ in Equation 3, i.e., VI . This is the relationship used to calculate active power in the ADE7756. The instantaneous power signal $p(t)$ is generated by multiplying the current and voltage signals. The dc component of the instantaneous power signal is then extracted by LPF2 (Low-Pass Filter) to obtain the active power information. This process is graphically illustrated in Figure 26. Since LPF2 does not have an ideal “brick wall” frequency response—see Figure 27—the Active Power signal will have some ripple due to the instantaneous power signal. This ripple is sinusoidal and has a frequency equal to twice the line frequency. Since the ripple is sinusoidal in nature it will be removed when the Active Power signal is integrated to calculate Energy—see Energy Calculation section.

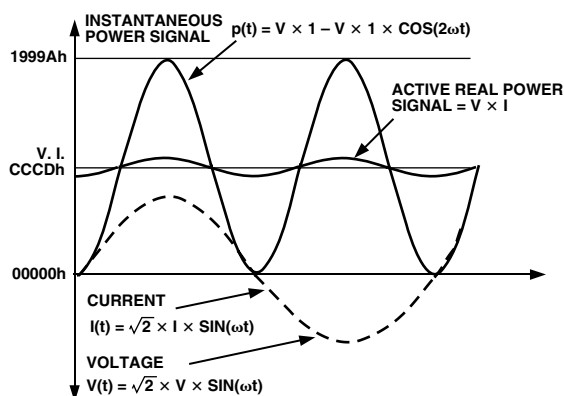

Figure 26. Active Power Calculation

Figure 28 shows the signal processing chain for the Active Power calculation in the ADE7756. As explained, the Active Power is calculated by low-pass filtering the instantaneous power signal.

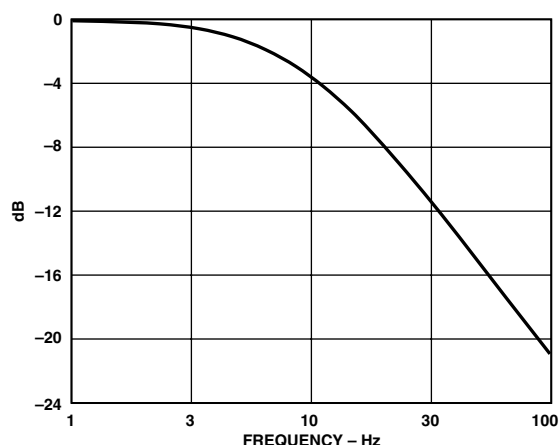

Figure 27. Frequency Response of LPF2

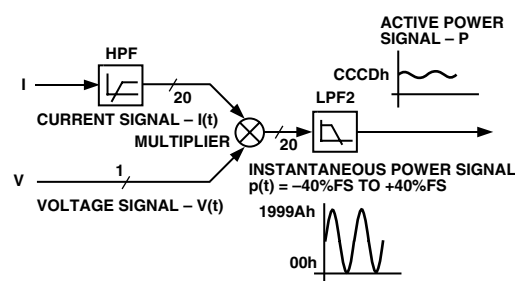

Figure 28. Active Power Signal Processing

Shown in Figure 29 is the maximum code (Hexadecimal) output range for the Active Power signal (LPF2). Note that the output range changes, depending on the contents of the Active Power Gain register—see Channel 1 ADC section. The minimum output range is given when the Active Power Gain register contents are equal to 800h, and the maximum range is given by writing 7FFh to the Active Power Gain register. This can be used to calibrate the Active Power (or Energy) calculation in the ADE7756.

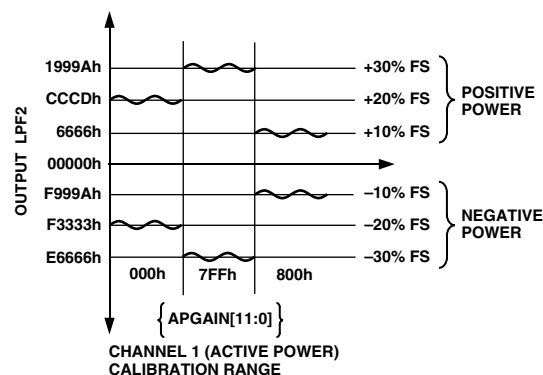

Figure 29. Active Power Calculation Output Range

ADE7756

ENERGY CALCULATION

As stated earlier, power is defined as the rate of energy flow. This relationship can be expressed mathematically as Equation 5.

$$P = \frac{dE}{dt} \quad (5)$$

where

P = Power, and
 E = Energy.

Conversely, Energy is given as the integral of Power.

$$E = \int P dt \quad (6)$$

The ADE7756 achieves the integration of the Active Power signal by continuously accumulating the Active Power signal in the 40-bit Active Energy register (AENERGY[39:0]). This discrete time accumulation or summation is equivalent to integration in continuous time. Equation 7 expresses the relationship

$$E = \int p(t) dt = \lim_{T \rightarrow 0} \left\{ \sum_{n=0}^{\infty} p(nT) \times T \right\} \quad (7)$$

where

n is the discrete time sample number

and

T is the sample period.

The discrete time sample period (T) for the accumulation register in the ADE7756 is $1.1 \mu\text{s}$ ($4/\text{CLKIN}$). As well as calculating the Energy, this integration removes any sinusoidal components that may be in the Active Power signal.

Figure 30 shows a graphical representation of this discrete time integration or accumulation. The Active Power signal in the Waveform register is continuously added to the Active Energy register. This addition is a signed addition, therefore negative energy will be subtracted from the Active Energy contents.

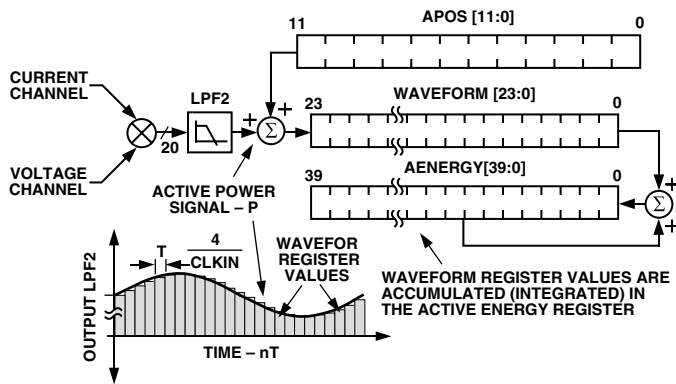

Figure 30. Energy Calculation

As shown in Figure 30, the Active Power signal is accumulated in a 40-bit signed register (AENERGY[39:0]).

The Active Power signal can be read from the Waveform register by setting MODE[14:13] = 0,0 and setting the WSMP bit (Bit 3) in the Interrupt Enable register to 1. Like the Channel 1 and Channel 2 waveform sampling modes, the waveform data is available at sample rates of 27.9 kSPS, 14 kSPS, 7 kSPS or 3.5 kSPS—see Figure 19.

Figure 31 shows this energy accumulation for full-scale signals (sinusoidal) on the analog inputs. The three curves displayed, illustrate the minimum period of time it takes the energy register to roll-over when the Active Power Gain register contents are 3FFh, 000h and 800h. The Active Power Gain register is used to carry out power calibration in the ADE7756. As shown, the fastest integration time will occur when the Active Power Gain register is set to maximum full scale, i.e., 3FFh.

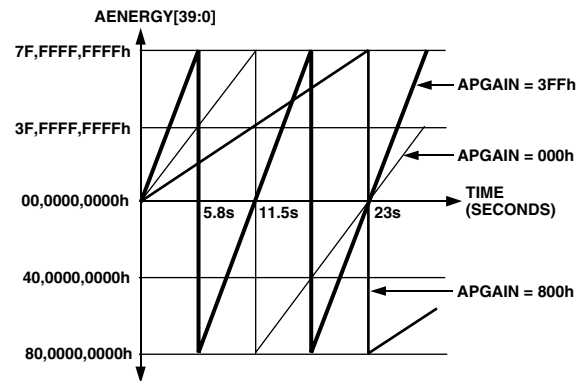

Figure 31. Energy Register Roll-Over Time for Full-Scale Power (Minimum and Maximum Power Gain)

Note that the energy register contents will roll over to full-scale negative (80,0000,0000h) and continue increasing in value when the power or energy flow is positive—see Figure 31. Conversely, if the power is negative the energy register would underflow to full-scale positive (7F, FFFF, FFFFh) and continue decreasing in value.

By using the Interrupt Enable register, the ADE7756 can be configured to issue an interrupt ($\overline{\text{IRQ}}$) when the Active Energy register is half-full (positive or negative) or when an over-/under-flow occurs.

Integration Times under Steady Load

As mentioned in the last section, the discrete time sample period (T) for the accumulation register is $1.1 \mu\text{s}$ ($4/\text{CLKIN}$). With full-scale sinusoidal signals on the analog inputs and the Active Power Gain register set to 000h, the average word value from LPF2 is CCCDh—see Figure 34. The maximum value that can be stored in the Active Energy register before it overflows is 2^{39} or 7F, FFFF, FFFFh. Therefore the integration time under these conditions is calculated as follows:

$$\text{Time} = \frac{7F, FFFF, FFFFh}{CCCDh} \times 1.1 \mu\text{s} = 11.53 \text{ seconds}$$

POWER OFFSET CALIBRATION

The ADE7756 also incorporates an Active Power Offset register (APOS[11:0]). This is a signed, two's complement, 12-bit register that can be used to remove offsets in the active power calculation—see Figure 30. An offset may exist in the power calculation due to crosstalk between channels on the PCB or in the IC itself. The offset calibration will allow the contents of the Active Power register to be maintained at zero when no power is being consumed.

Sixteen LSBs (APOS = 010h) written to the Active Power Offset register are equivalent to 1 LSB in the Waveform Sample register. Assuming the average value outputs from LPF2 to store in the Waveform Register is CCCDh (52,429 in Decimal) when inputs on Channels 1 and 2 are both at full scale. At -60 dB down on Channel 1 (1/1000 of the full-scale input), the average word value outputs from LPF2 is 52.429 (52,429/1,000). 1 LSB in the Waveform register has a measurement error of $1/52.429 \times 100\% = 1.9\%$ of the average value. The Active Power Offset register has a resolution equal to 1/16 LSB of the Waveform register, hence the power offset correction resolution is 0.12% (1.9%/16) at -60 dB.

ENERGY-TO-FREQUENCY CONVERSION

ADE7756 also provides energy-to-frequency conversion for calibration purposes. After initial calibration at manufacture, the manufacturer or end customer will often verify the energy meter calibration. One convenient way to verify the meter calibration is for the manufacturer to provide an output frequency that is proportional to the energy or active power under steady load conditions. This output frequency can provide a simple, single wire, optically isolated interface to external calibration equipment. Figure 32 illustrates the Energy-to-Frequency conversion in the ADE7756.

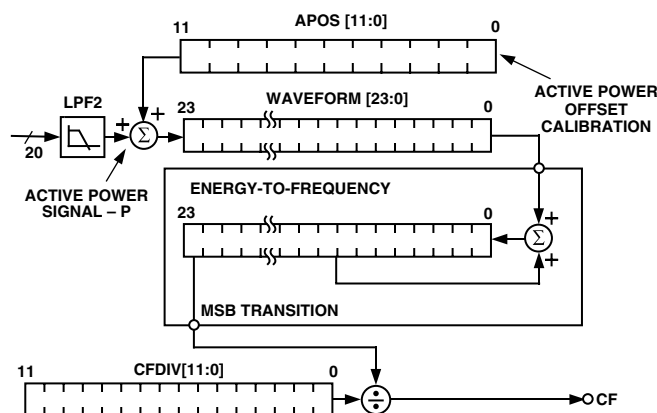

Figure 32. Energy-to-Frequency Conversion

The energy-to-frequency conversion is accomplished by accumulating the Active power signal in a 24-bit register. An output pulse is generated when there is a zero to one transition on the MSB (most significant bit) of the register. Under steady load conditions the output frequency is proportional to the Active Power.

The output frequency at CF, with full-scale ac signals on Channel 1 and Channel 2 and CFDIV = 000h and APGAIN = 000h, is approximately 5.593 kHz. This can be calculated as follows: with the Active Power Gain register set to 000h, the average value of the instantaneous power signal (output of LPF2) is CCCDh or 52,429 decimal. An output frequency is generated

on CF when the MSB in the Digital-to-Frequency register (24 bits) toggles, i.e., when the register accumulates 2^{23} . This means the register is updated $2^{23}/\text{CCCDh}$ times (or 159.999 times). Since the update rate is 4/CLKIN or 1.1175 μs , the time between MSB toggles (CF pulses) is given as:

$$159.999 \times 1.1175 \mu\text{s} = 1.78799 \times 10^{-4}\text{s} = 5592.86 \text{ Hz.}$$

Equation 8 gives an expression for the output frequency at CF with the CFDIV register = 0.

$$CF(\text{Hz}) = \frac{\text{Average LPF2 Output} \times \text{CLKIN}}{2^{25}} \quad (8)$$

This output frequency is easily scaled by the Calibration Frequency Division register (CFDIV[11:0]). This frequency scaling register is a 12-bit register that scales the output frequency by 1 to 2^{12} . The output frequency is given in Equation 9.

$$\text{Frequency} = \frac{\text{Frequency (CFDIV} = 0)}{\text{CFDIV} + 1} \quad (9)$$

For example, if the output frequency is 5.59286 kHz while the content of CFDIV is zero (000h), the output frequency can be set to 5.4618 Hz by writing 3FFh Hex (1023 Decimal) to the CFDIV register. The power-up default value in CFDIV is 3Fh.

The output frequency will have a slight ripple at a frequency equal to twice the line frequency. This is due to imperfect filtering of the instantaneous power signal to generate the Active Power signal—see Active Power Calculation section. Equation 3 gives an expression for the instantaneous power signal. This is filtered by LPF2, which has a magnitude response given by Equation 10.

$$|H(f)| = \frac{1}{1 + f/8.9 \text{ Hz}} \quad (10)$$

The Active Power signal (output of LPF2) can be rewritten as

$$p(t) = VI - \left(\frac{VI}{1 + 2 fl / 8.9 \text{ Hz}} \right) \cos(4 \times \pi \times fl \times t) \quad (11)$$

where fl is the line frequency (e.g., 60 Hz)

From Equation 6

$$E(t) = VI t - \left(\frac{VI}{4 \times \pi \times fl(1 + 2 fl / 8.9 \text{ Hz})} \right) \sin(4 \times \pi \times fl \times t) \quad (12)$$

From Equation 12 it can be seen that there is a small ripple in the energy calculation due to a $\sin(2 \omega t)$ component. This is shown graphically in Figure 33. The Active Energy calculation is shown by the dashed straight line and is equal to $V \times I \times t$. The sinusoidal ripple in the Active Energy calculation is also shown. Since the average value of a sinusoid is zero, this ripple will contribute nothing to the energy calculation over time. However, the ripple can be observed in the frequency output, especially at higher output frequencies. The ripple will get larger as a percentage of the frequency at larger loads and higher output frequencies. The reason is simply that at higher output frequencies the integration or averaging time in the energy-to-frequency conversion process is shorter. As a consequence, some of the sinusoidal ripple is observable in the frequency output. Choosing a lower output frequency at CF for calibration can significantly

ADE7756

reduce the ripple. Also, averaging the output frequency by using a longer gate time for the counter will achieve the same results.

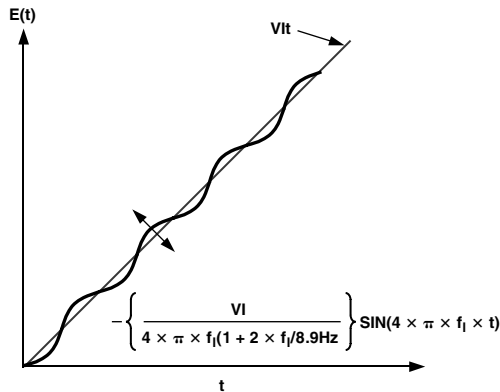

Figure 33. Output Frequency Ripple

ENERGY CALIBRATION

By using the on-chip zero-crossing detection on Channel 2 the energy calibration can be greatly simplified and the time required to calibrate the meter can be significantly reduced. To use the zero-cross detection the ADE7756 is placed in calibration mode by setting Bit 7 (CMODE) in the Mode register. In Calibration Mode the ADE7756 accumulates the Active Power signal in the Active Energy register for an integral number of half cycles, as shown in Figure 34. The number of half-line cycles is specified in the SAGCYC register. The ADE7756 can accumulate Active Power for up to 255 half-cycles. Because the Active Power is integrated on an integral number of line cycles, the sinusoidal component is reduced to zero. This eliminates any ripple in the energy calculation. Energy is calculated more accurately and in a shorter time because integration period can be shortened. At the end of an energy calibration cycle the SAG flag in the Interrupt Status register is set; this will cause the SAG output to go active low. If the SAG enable bit in the Interrupt Enable register is enabled, the $\overline{\text{IRQ}}$ output will also go active low. Thus the $\overline{\text{IRQ}}$ line can be used to signal the end of a calibration also. Another calibration cycle will start as long as the CMODE bit in the Mode register is set. Note that the result of the first calibration is invalid and must be ignored. The result of all subsequent calibration cycles is correct.

From Equations 5 and 11,

$$E(t) \int_0^{nT} VI dt - \left(\frac{VI}{1 + 2 \cdot fl / 8.9 \text{ Hz}} \right) \int_0^{nT} \cos(2 \omega t) dt \quad (13)$$

where n is an integer and T is the line cycle period. Since the sinusoidal component is integrated over an integer number of line cycles, its value is always zero.

Therefore:

$$E(t) = \int_0^{nT} VI dt \quad (14)$$

$$E(t) = VI nt \quad (15)$$

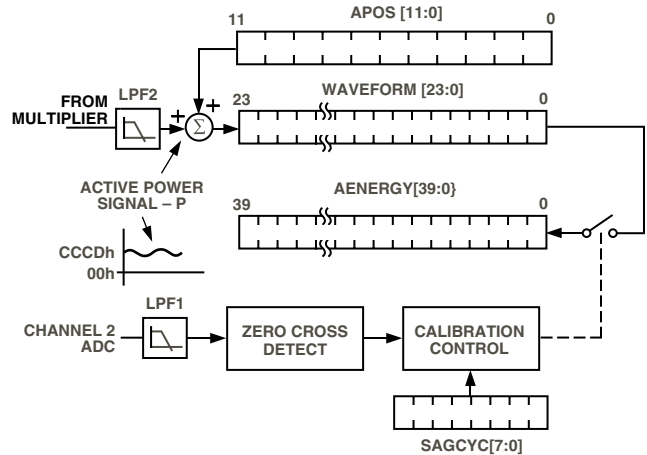

Figure 34. Energy Calculation in Calibration Mode

CALIBRATING THE ENERGY METER

Calculating the Average Active Power

When calibrating the ADE7756, the first step is to calibrate the frequency on CF to some required meter constant, e.g., 3200 imp/kWh.

In order to determine the output frequency on CF, the average value of the Active Power signal (output of LPF2) must first be determined. One convenient way to do this is to use the calibration mode. When the CMODE (Bit 7) bit in the Mode register is set to a Logic 1, energy is accumulated over an integer number of half-line cycles as described in the last section.

Since the line frequency is fixed at, say, 60 Hz, and the number of half-cycles of integration is specified, the total integration time is given as:

$$\frac{1}{2 \times 60 \text{ Hz}} \times \text{number of half cycles}$$

For 255 half-cycles this would give a total integration time of 2.125 seconds. This would mean the energy register was updated $2.125 / 1.1175 \mu\text{s}$ ($4 / \text{CLKIN}$) times. The average output value of LPF2 is given as:

$$\frac{\text{Contents of AENERGY}[39:0] \text{ at the end}}{\text{Number of times AENERGY}[39:0] \text{ was updated}}$$

Or equivalently, in terms of contents of various ADE7756 registers and CLKIN and line frequencies (fl):

$$\text{Average word (LPF2)} = \frac{\text{AENERGY}[39:0] \times 8 \times fl}{\text{SAGCYC}[7:0] \times \text{CLKIN}} \quad (16)$$

where fl is the line frequency.

Calibrating the Frequency at CF

Once the average Active Power signal is calculated it can be used to determine the frequency at CF before calibration. When the frequency before calibration is known, the Calibration Frequency Divider register (CFDIV) and the Active Power Gain register (APGAIN) can be adjusted to produce the required frequency on CF. In this example, a meter constant of 3200 imp/kWh is chosen as an appropriate constant. This means that under a steady load of 1 kW, the output frequency on CF would be,

$$\text{Frequency (CF)} = \frac{3200 \text{ imp/kWh}}{60 \text{ min} \times 60 \text{ sec}} = \frac{3200}{3600} = 0.8888 \text{ Hz}$$

Assuming the meter is set up with a test current (basic current) of 20 A and a line voltage of 220 V for calibration, the load is calculated as $220\text{ V} \times 20\text{ A} = 4.4\text{ kW}$. Therefore the expected output frequency on CF under this steady load condition would be $4.4 \times 0.8888\text{ Hz} = 3.9111\text{ Hz}$.

Under these load conditions the transducers on Channel 1 and Channel 2 should be selected such that the signal on the voltage channel should see approximately half scale and the signal on the current channel about 1/8 of full scale (assuming a maximum current of 80A). The average value from LPF2 is calculated as 3,276.81 decimal using the calibration mode as described above. Then, using Equation 8 (Energy to Frequency Conversion), the frequency under this load is calculated as:

$$\text{Frequency (CF)} = \frac{3276.81 \times 3.579545\text{ MHz}}{2^{25}} = 349.566\text{ Hz}$$

However, this is the frequency with the contents of the CFDIV and APGAIN registers equal to 000h. The desired frequency out is 3.9111 Hz. Therefore the CF frequency must be divided by $349.566/3.9111\text{ Hz}$ or 89.378 decimal. This is achieved by loading the CF Divide register with 88 (or 58h)—Note the CF frequency is divided by the contents of CFDIV + 1.

The fine adjustment of the output frequency can be made using the Active Power Gain register. This register has a fine gain adjustment of 0.0244%/LSB. With the CF Divide register contents equal to 58h, the output frequency is given as $349.556\text{ Hz}/89 = 3.9276\text{ Hz}$. This setting has an error of 0.42%. This error can be further reduced by writing $-(0.21/0.0244)$ or -17 to APGAIN[11:0] i.e., FEFh.

Calibrating CF is made easy by using the Calibration mode on the ADE7756. The only critical part of the setup is that the line frequency be exactly known. If this is not possible, it could be measured by using the ZX output of the ADE7756.

Energy Meter Display

Besides the pulse output which is used to verify calibration, a solid state energy meter will very often require some form of display. The display should display the amount of energy consumed in kWh (Kilowatt Hours). One convenient and simple way to interface the ADE7756 to a display or energy register (e.g., MCU with nonvolatile memory) is to use CF. For example the CF frequency could be calibrated to 1,000 imp/kWh. The MCU would count pulses from CF. Every pulse would be equivalent to 1 watt-hour. If more resolution is required the CF frequency could be set to, say, 10,000 imp/kWh.

If more flexibility is required when monitoring energy usage, the Active Energy register (AENERGY) can be used to calculate energy. A full description of this register can be found in the Energy Calculation section. The AENERGY register gives the user both sign and magnitude information regarding energy consumption. On completion of the CF frequency output calibration, i.e., after the Active Power Gain (APGAIN) register has been adjusted, a second calibration sequence can be initiated. The purpose of this second calibration routine is to determine a kWh/LSB coefficient for the AENERGY register. Once the coefficient has been calculated the MCU can determine the energy consumption at any time by reading the AENERGY contents and multiplying by the coefficient to calculate kWh.

CLKIN FREQUENCY

In this data sheet, the characteristics of the ADE7756 are shown with CLKIN frequency equal to 3.579545 MHz. However, the ADE7756 is designed to have the same accuracy at any CLKIN frequency within the specified range. If the CLKIN frequency is not 3.579545 MHz, various timing and filter characteristics will need to be redefined with the new CLKIN frequency. For example, the cut-off frequencies of all digital filters (LPF1, LPF2, HPF1, etc.) will shift in proportion to the change in CLKIN frequency according to the following equation:

$$\text{New Frequency} = \text{Original Frequency} \times \frac{\text{CLKIN Frequency}}{3.579545\text{ MHz}} \quad (17)$$

The change of CLKIN frequency does not affect the timing characteristics of the serial interface because the data transfer is synchronized with serial clock signal (SCLK). But one needs to observe the read/write timing of the serial data transfer—see Timing Characteristics. Table III lists various timing changes that are affected by CLKIN frequency.

APPLICATION INFORMATION

Application note AN-564 contains detail information on how to design a ANSI Class 100 Watt-Hour meter based on the ADE7756. It is available from the ADE7756 product home page under the Application Note link. Figure 35 shows the block diagram of the ADE7756 reference meter implemented in AN-564.

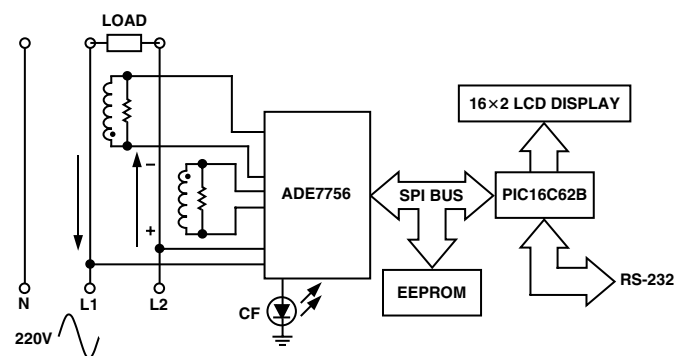

Figure 35. Block Diagram of the ADE7756 Reference Meter Described in AN-564

Table III. Frequency Dependencies of the ADE7756 Parameters

Parameter	CLKIN Dependency
Nyquist Frequency for CH 1 and 2 ADCs	CLKIN/8
PHCAL Resolution (Seconds per LSB)	16/CLKIN
Active Energy Register Update Rate (Hz)	CLKIN/4
Waveform Sampling Rate (Number of Samples per Second)	
WAVSEL 1, 0 = 0 0	CLKIN/128
0 1	CLKIN/256
1 0	CLKIN/512
1 1	CLKIN/1024
Maximum ZXTOUT Period	524,288/CLKIN

ADE7756

SUSPENDING THE ADE7756 FUNCTIONALITY

The analog and the digital circuit can be suspended separately. The analog portion of the ADE7756 can be suspended by setting the ASUSPEND bit (Bit 4) of the Mode register to logic high—see Mode Register section. In suspend mode, all waveform samples from the ADCs will be set to zeros. The digital circuitry can be halted by holding the CLKIN input to 0 or 1. The ADE7756 can be reactivated by restoring the CLKIN input and setting the ASUSPEND bit to logic low.

SERIAL INTERFACE

All ADE7756 functionality is accessible via several on-chip registers—see Figure 36. The contents of these registers can be updated or read using the on-chip serial interface. After power-on, or toggling the RESET pin low, on a falling edge on CS, the ADE7756 is placed in Communications Mode. In Communications Mode the ADE7756 expects a write to its Communications register. The data written to the Communications register determines whether the next data transfer operation will be a read or a write and also which register is accessed. Therefore all data transfer operations with the ADE7756, whether a read or a write, must begin with a write to the Communications register.

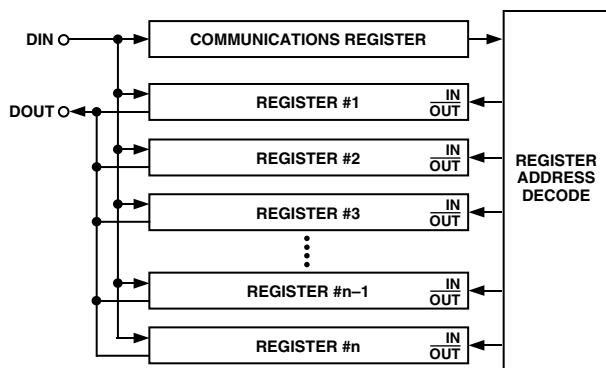

Figure 36. Addressing ADE7756 Registers via the Communications Register

The Communications register is an 8-bit-wide register. The MSB determines whether the next data transfer operation is a read or a write. The 5 LSBs contain the address of the register to be accessed. See Communications Register section for a more detailed description.

Figure 37a and 37b show the data transfer sequences for a read and write operation respectively.

On completion of a data transfer (read or write) the ADE7756 once again enters Communications Mode.

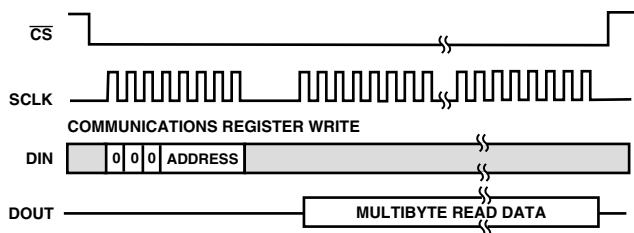

Figure 37a. Data from the ADE7756 via the Serial Interface

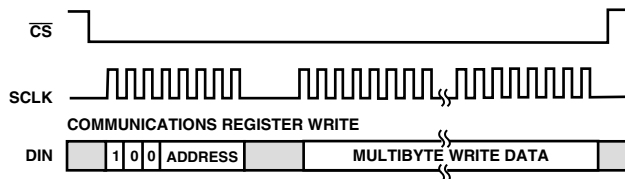

Figure 37b. Writing Data to the ADE7756 via the Serial Interface

A data transfer is complete when the LSB of the ADE7756 register being addressed (for a write or a read) is transferred to or from the ADE7756.

The Serial Interface of the ADE7756 is made up of four signals SCLK, DIN, DOUT, and CS. The serial clock for a data transfer is applied at the SCLK logic input. This logic input has a Schmitt-trigger input structure, which allows slow rising (and falling) clock edges to be used. All data transfer operations are synchronized to the serial clock. Data is shifted into the ADE7756 at the DIN logic input on the falling edge of SCLK. Data is shifted out of the ADE7756 at the DOUT logic output on a rising edge of SCLK. The CS logic input is the chip select input. This input is used when multiple devices share the serial bus. A falling edge on CS also resets the serial interface and places the ADE7756 in Communications Mode. The CS input should be driven low for the entire data transfer operation. Bringing CS high during a data transfer operation will abort the transfer and place the serial bus in a high impedance state. The CS logic input may be tied low if the ADE7756 is the only device on the serial bus. However, with CS tied low all initiated data transfer operations must be fully completed, i.e., the LSB of each register must be transferred as there is no other way of bringing the ADE7756 back into Communications Mode without resetting the entire device, i.e., using RESET.

Serial Write Operation

The serial write sequence takes place as follows. With the ADE7756 in Communications Mode (i.e., the CS input logic low), a write to the Communications register first takes place. The MSB of this byte transfer is a 1, indicating that the data transfer operation is a write. The LSBs of this byte contain the address of the register to be written to. The ADE7756 starts shifting in the register data on the next falling edge of SCLK. All remaining bits of register data are shifted in on the falling edge of subsequent SCLK pulses—see Figure 38.

As explained earlier, the data write is initiated by a write to the communications register followed by the data. During a data write operation to the ADE7756, data is transferred to all on-chip registers one byte at a time. After a byte is transferred into the serial port, there is a finite time before it is transferred to one of the ADE7756 on-chip registers. Although another byte transfer to the serial port can start while the previous byte is being transferred to an on-chip register, this second byte transfer should not finish until at least 4 μs after the end of the previous byte transfer. This functionality is expressed in the timing specification t_6 —see Figure 38. If a write operation is aborted during a byte transfer (CS brought high), that byte will not be written to the destination register.

Destination registers may be up to 2 bytes wide—see Register Descriptions section. Hence the first byte shifted into the serial port at DIN is transferred to the MSB (Most Significant Byte) of the destination register. If the addressed register is 12 bits

wide, for example, a 2-byte data transfer must take place. The data is always assumed to be right justified, therefore, in this case, the 4 MSBs of the first byte would be ignored and the 4 LSBs of the first byte written to the ADE7756 would be the 4 MSBs of the 12-bit word. Figure 39 illustrates this example.

Serial Read Operation

During a data read operation from the ADE7756, data is shifted out at the DOUT logic output on the rising edge of SCLK. As was the case with the data write operation, a data read must be preceded with a write to the Communications register.

With the ADE7756 in Communications Mode (i.e., \overline{CS} logic low) an 8-bit write to the Communications register first takes place. The MSB of this byte transfer is a 0, indicating that the next data transfer operation is a read. The LSBs of this byte contain the address of the register to be read. The ADE7756 starts shifting out of the register data on the next rising edge of SCLK—see Figure 40. At this point the DOUT logic output leaves its high impedance state and starts driving the data bus.

All remaining bits of register data are shifted out on subsequent SCLK rising edges. The serial interface also enters Communications Mode again as soon as the read has been completed. At this point the DOUT logic output enters a high impedance state on the falling edge of the last SCLK pulse. The read operation may be aborted by bringing the \overline{CS} logic input high before the data transfer is complete. The DOUT output enters a high impedance state on the rising edge of \overline{CS} .

When an ADE7756 register is addressed for a read operation, the entire contents of that register are transferred to the serial port. This allows the ADE7756 to modify its on-chip registers without the risk of corrupting data during a multibyte transfer. Note when a read operation follows a write operation, the read command (i.e., write to communications register) should not happen for at least 4 μs after the end of the write operation. If the read command is sent within 4 μs of the write operation, the last byte of the write operation may be lost. This is given as timing specification t_9 .

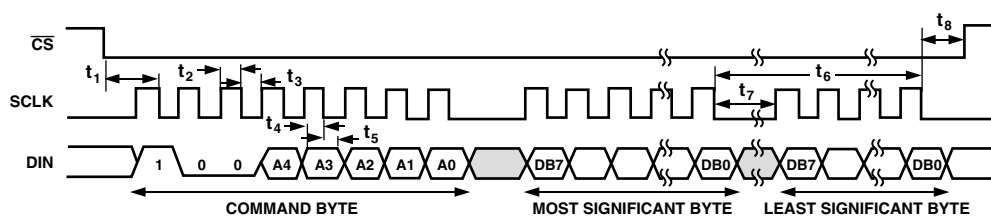

Figure 38. Serial Interface Write Timing Diagram

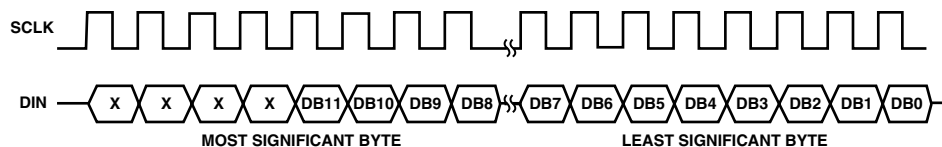

Figure 39. 12-Bit Serial Write Operation

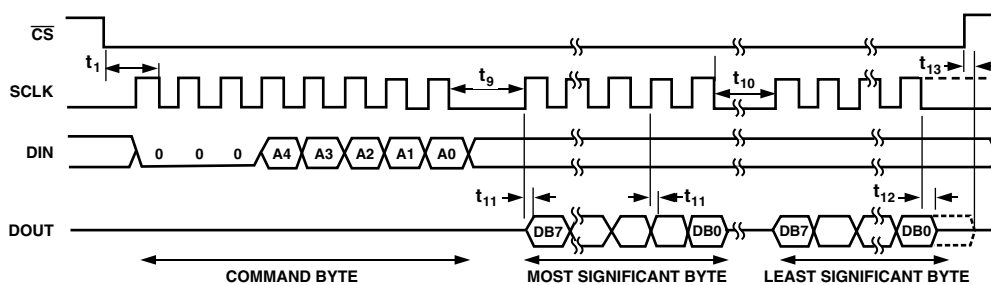

Figure 40. Serial Interface Read Timing Diagram

Table IV. Register List

Address	Name	R/W	No. of Bits	Default	Description
00h	Not Used				No Operation.
01h	WAVEFORM	R	24	0h	The Waveform register is a 24 bit read-only register. This register contains the sampled waveform data from either Channel 1, Channel 2 or the Active Power signal. The data source is selected by data bits 14 and 13 in the Mode Register—see Channel 1 and 2 Sampling sections.
02h	AENERGY	R	40	0h	The Active Energy Register. Active Power is accumulated (Integrated) over time in this 40-bit, read-only register. The energy register can hold a minimum of 6 seconds of Active Energy information with full-scale analog inputs before it overflows—see Energy Calculation section.
03h	RSTENERGY	R	40	0h	Same as the Active Energy register except that the register is reset to zero following a read operation
04h	STATUS	R	8	0h	The Interrupt Status Register. This is an 8-bit read-only register. The Status Register contains information regarding the source of ADE7756 interrupts—see Interrupts section.
05h	RSTSTATUS	R	8	0h	Same as the Interrupt Status register except that the register contents are reset to zero (all flags cleared) after a read operation.
06h	MODE	R/W	16	000Ch	The Mode Register. This is a 16-bit register through which most of the ADE7756 functionality is accessed. Signal sample rates, filter enabling and calibration modes are selected by writing to this register. The contents may be read at any time—see Mode Register section.
07h	CFDIV	R/W	12	3Fh	The Frequency Divider Register. This is a 12-bit read/write register. The output frequency on the CF pin is adjusted by writing to this register—see Energy to Frequency Conversion section.
08h	CH1OS	R/W	6	0h	Channel 1 Offset Adjust. Writing to this 6-bit register allows any offsets on Channel 1 to be removed—see Analog Inputs section.
09h	CH2OS	R/W	6	0h	Channel 2 Offset Adjust. Writing to this 6-bit register allows any offsets on Channel 2 to be removed—see Analog Inputs section.
0Ah	GAIN	R/W	8	0h	PGA Gain Adjust. This 8-bit register is used to adjust the gain selection for the PGA in Channel 1 and Channel 2—Analog Inputs section.
0Bh	APGAIN	R/W	12	0h	Active Power Gain Adjust. This is a 12-bit register. The Active Power calculation can be calibrated by writing to this register. The calibration range is $\pm 50\%$ of the nominal full scale active power. The resolution of the gain adjust is 0.0244%/LSB—see Channel 1 ADC Gain Adjust section.
0Ch	PHCAL	R/W	6	0h	Phase Calibration Register. The phase relationship between Channel 1 and Channel 2 can be adjusted by writing to this 6-bit register. The adjustment range is approximately $\pm 3.1^\circ$ at 60 Hz in 0.097° steps—see Phase Compensation section.
0Dh	APOS	R/W	12	8h	Active Power Offset Correction. This 12-bit register allows small offsets in the Active Power Calculation to be removed—see Active Power Calculation section.
0Eh	ZXTOUT	R/W	12	FFFh	Zero-Cross Time Out. If no zero crossings are detected on Channel 2 within a time period specified by this 12-bit register, the interrupt request line ($\overline{\text{IRQ}}$) will be activated. The maximum time-out period is 0.15 second—see Zero Crossing Detection section.
0Fh	SAGCYC	R/W	8	FFh	Sag Line Cycle Register. This 8-bit register specifies the number of consecutive half line cycles the signal on Channel 2 must be below SAGLVL before the SAG output is activated—see Voltage Sag Detection section. It is also used during calibration mode to set the number of line cycles Active power is accumulated for Energy calibration—see Energy Calibration section.

Table IV. Register List (continued)

Address	Name	R/W	No. of Bits	Default	Description
10H	IRQEN	R/W	8	0h	Interrupt Enable Register. ADE7756 interrupts may be deactivated at any time by setting the corresponding bit in this 8-bit Enable register Logic 0. The Status register will continue to register an interrupt event even if disabled. However, the $\overline{\text{IRQ}}$ output will not be activated—see Interrupts section.
11H	SAGLVL	R/W	8	0h	Sag Voltage Level. An 8-bit write to this register determines at what peak signal level on Channel 2 the SAG pin will become active. The signal must remain low for the number of cycles specified in the SAGCYC register before the SAG pin is activated—see Line Voltage Sag Detection section.
12H	TEMP	R	8	0h	Temperature Register. This is an 8-bit register which contains the result of the latest temperature conversion. A full description of this register's contents can be found in the Temperature Measurement section of this data sheet.

REGISTER DESCRIPTIONS

All ADE7756 functionality is accessed via the on-chip registers. Each register is accessed by first writing to the communications register and then transferring the register data. A full description of the serial interface protocol is given in the Serial Interface section of this data sheet.

Communications Register

The Communications register is an 8-bit, write-only register that controls the serial data transfer between the ADE7756 and the host processor. All data transfer operations must begin with a write to the communications register. The data written to the communications register determines whether the next operation is a read or a write and which register is being accessed. Table V outlines the bit designations for the Communications register.

Table V. Communications Register

DB7	DB6	DB5	DB4	DB3	DB2	DB1	DB0
$\overline{\text{W/R}}$	0	0	A4	A3	A2	A1	A0

Bit Location	Bit Mnemonic	Description
0 to 4	A0 to A4	The five LSBs of the Communications register specify the register for the data transfer operation. Table IV lists the address of each ADE7756 on-chip register.
5 to 6	RESERVED	These bits are unused and should be set to zero.
7	$\overline{\text{W/R}}$	When this bit is a Logic 1, the data transfer operation immediately following the write to the Communications register will be interpreted as a write to the ADE7756. When this bit is a Logic 0, the data transfer operation immediately following the write to the Communications register will be interpreted as a read operation.

ADE7756

Mode Register (06H)

The ADE7756 functionality is configured by writing to the MODE register. Table VI summarizes the functionality of each bit in the MODE register.

Table VI. Mode Register

Bit Location	Bit Mnemonic	Description															
0	DISHPF	The HFP (High-Pass Filter) in Channel 1 is disabled when this bit is set.															
1	DISLPF2	The LPF (Low-Pass Filter) after the multiplier (LPF2) is disabled when this bit is set.															
2	DISCF	The frequency output CF is disabled when this bit is set.															
3	DISSAG	The line voltage Sag detection is disabled when this bit is set.															
4	ASUSPEND	By setting this bit to Logic 1, both ADE7756's A/D converters can be turned off. In normal operation, this bit should be left at Logic 0. All digital functionality can be stopped by suspending the clock signal at CLKIN pin.															
5	TEMPSEL	The temperature conversion starts when this bit is set to one. This bit is automatically reset to zero when the temperature conversion is finished.															
6	SWRST	Software Chip Reset. A data transfer should not take place to the ADE7756 for at least 18 μs after a software reset.															
7	CMODE	Setting this bit to a Logic 1 places the chip in calibration mode.															
8	DISCH1	ADC 1 (Channel 1) inputs are internally shorted together.															
9	DISCH2	ADC 2 (Channel 2) inputs are internally shorted together.															
10	SWAP	By setting this bit to Logic 1 the analog inputs V2P and V2N are connected to ADC 1 and the analog inputs V1P and V1N are connected to ADC 2.															
12, 11	DTRT1, 0	These bits are used to select the Waveform Register update rate. <table border="1" style="margin-left: 20px;"> <thead> <tr> <th>DTRT 1</th> <th>DTRT0</th> <th>Update Rate</th> </tr> </thead> <tbody> <tr> <td>0</td> <td>0</td> <td>27.9 kSPS (CLKIN/128)</td> </tr> <tr> <td>0</td> <td>1</td> <td>14 kSPS (CLKIN/256)</td> </tr> <tr> <td>1</td> <td>0</td> <td>7 kSPS (CLKIN/512)</td> </tr> <tr> <td>1</td> <td>1</td> <td>3.5 kSPS (CLKIN/1024)</td> </tr> </tbody> </table>	DTRT 1	DTRT0	Update Rate	0	0	27.9 kSPS (CLKIN/128)	0	1	14 kSPS (CLKIN/256)	1	0	7 kSPS (CLKIN/512)	1	1	3.5 kSPS (CLKIN/1024)
DTRT 1	DTRT0	Update Rate															
0	0	27.9 kSPS (CLKIN/128)															
0	1	14 kSPS (CLKIN/256)															
1	0	7 kSPS (CLKIN/512)															
1	1	3.5 kSPS (CLKIN/1024)															
14, 13	WAVSEL1, 0	These bits are used to select the source of the sampled data for the Waveform Register <table border="1" style="margin-left: 20px;"> <thead> <tr> <th>WAVSEL1</th> <th>WAVSEL0</th> <th>Source</th> </tr> </thead> <tbody> <tr> <td>0</td> <td>0</td> <td>Active Power signal (output of LPF2)</td> </tr> <tr> <td>0</td> <td>1</td> <td>RESERVED</td> </tr> <tr> <td>1</td> <td>0</td> <td>Channel 1</td> </tr> <tr> <td>1</td> <td>1</td> <td>Channel 2</td> </tr> </tbody> </table>	WAVSEL1	WAVSEL0	Source	0	0	Active Power signal (output of LPF2)	0	1	RESERVED	1	0	Channel 1	1	1	Channel 2
WAVSEL1	WAVSEL0	Source															
0	0	Active Power signal (output of LPF2)															
0	1	RESERVED															
1	0	Channel 1															
1	1	Channel 2															
15	TEST1	Writing a Logic 1 to this bit position places the ADE7756 in test mode. This is intended for factory testing only and should be left at zero.															

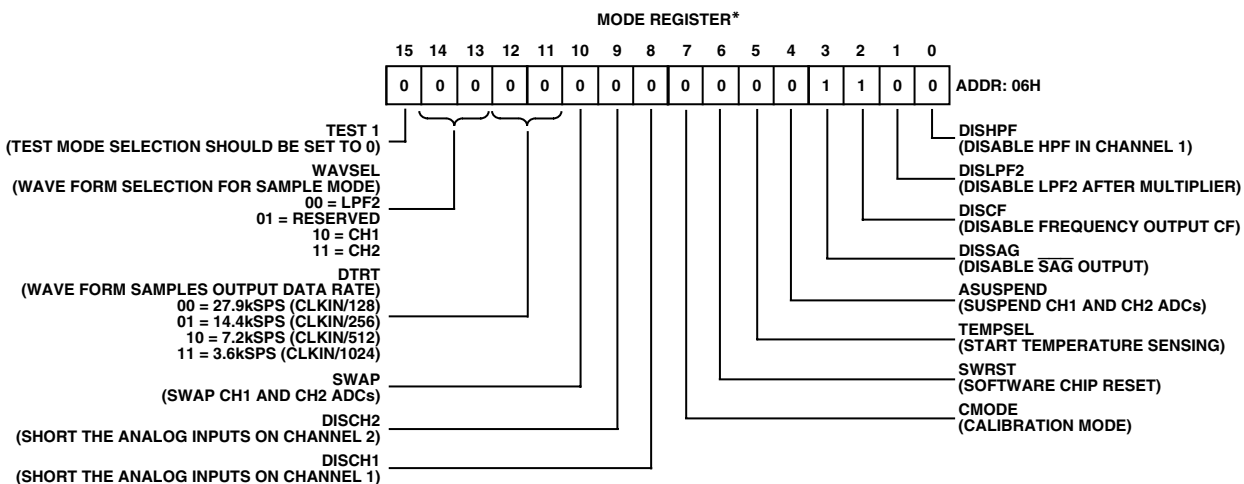

*REGISTER CONTENTS SHOW POWER-ON DEFAULTS

Figure 41.

Interrupt Status Register (04H) / Reset Interrupt Status Register (05H)

The Status register is used by the MCU to determine the source of an interrupt request (\overline{IRQ}). When an interrupt event occurs in the ADE7756, the corresponding flag in the Interrupt Status register is set logic high. If the enable bit for this flag is Logic 1 in the Interrupt Enable register, the \overline{IRQ} logic output goes active low. When the MCU services the interrupt it must first carry out a read from the Interrupt Status register to determine the source of the interrupt.

Table VII. Interrupt Status Register, Reset Interrupt Status Register and Interrupt Enable Register

Bit Location	Interrupt Flag	Description
0	AEHF	Indicates that an interrupt was caused by the 0 to 1 transition of the MSB of the Active Energy register.
1	SAG	Indicates that an interrupt was caused by a SAG on the line voltage or no zero crossings were detected. In calibration mode this flag is also used to indicate the end of an integration over an integer number of half line cycles—see Energy Calibration section.
3	WSMP	Indicates that new data is present in the Waveform register.
4	ZX	This status bit reflects the status of the ZX logic output—see Zero Crossing Detection section.
5	TEMP	Indicates that a temperature conversion result is available in the Temperature register.
7	AEOF	Indicates that the Active Energy register has overflowed.

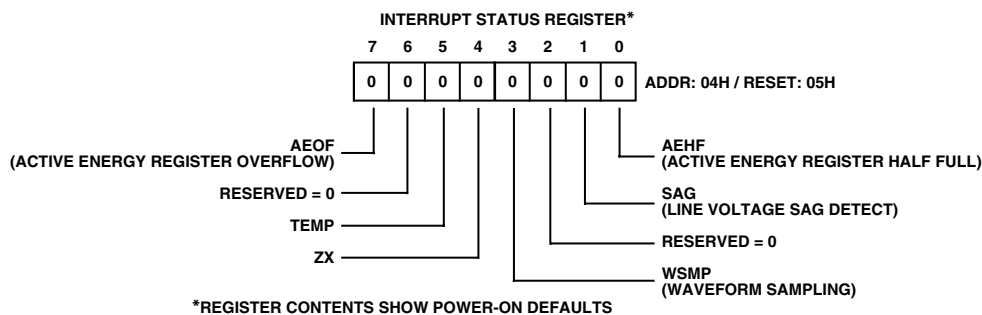

Figure 42. Interrupt Status Register

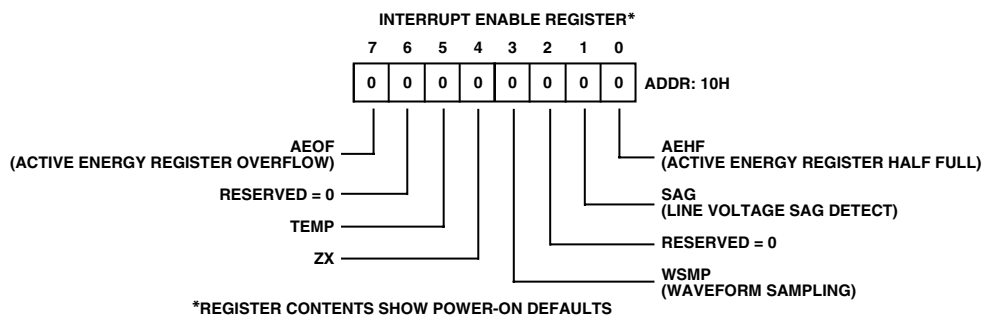
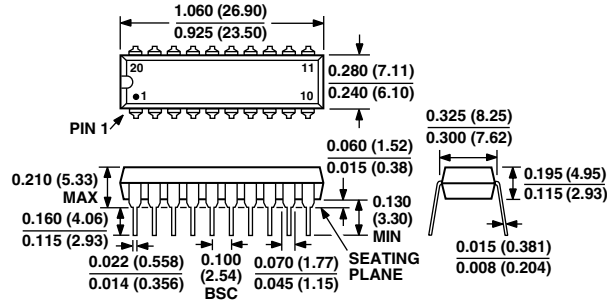

Figure 43. Interrupt Enable Register

OUTLINE DIMENSIONS

Dimensions shown in inches and (mm).

**20-Lead Plastic DIP
(N-20)**



**20-Lead Shrink Small Outline Package
(RS-20)**

